



N-Series Digital Wireless Microphone System User Guide

Introduction	6
Quick start guide	7
Getting started	14
Tuning the system	14
Performing a QUICK SETUP	15
Performing manual set up of group and channels	17
Performing manual set up of frequency	18
Synchronizing a Transmitter	18
N-DR1 Digital Dual Channel Receiver	19
Included in the box	19
Hardware overview	19
Installation	21
Antenna cables	22
Operation	23
Main and detailed screens	23
Menu system	24
Main menu	26
Functions and settings	26
Headphone mode	26
Display brightness	27
Primary	32
IP address	33
Subnet	33
Gateway	33
MAC address	33
Date and time	33
Date	34
Time	34
Transmitter Firmware update	34
Factory restore	34
Device information	34
Channel Menu	34
Functions and settings	35
QUICK SETUP	35
Channel name	35

Radio	36
Encryption	36
Keep TX settings	37
Transmitter settings	37
Audio low-cut	37
Function key	38
Menu lock	38
RF Power	38
Battery Type	39
Battery status	39
Information (Tx)	39
Receiver	39
Mute	40
Audio polarity	40
Audio trim	41
Analog reference	41
Analog type	41
Audio level and trim	43
Networking and Dante®	44
Control network	44
Connecting to an External Control System	46
Mixing and the control network	47
DPA Audio Controller Software	47
Reading the meters	48
Audio level	48
Radio strength	48
N-BP1 (N-BP1-90 and N-BP1-03) Bodypack Transmitters	49
Included in the box	49
Hardware overview	49
Batteries	50
Connector types	51
Interface schematics	51
Instrument cables	52
N-HH1-SL1 Handheld Transmitter	53
Included in the box	53

Hardware overview	53
Batteries	54
Changing the identification ring	55
Operating Transmitters	55
Powering on and off, and muting the Transmitter	55
Main screens	58
How to navigate the menu system	58
Functions and settings	59
Firmware updates	62
N-DR1 Receiver	62
N-BP1 (N-BP1-90, N-BP1-03) & N-HH1-SL1 Transmitters	62
Cleaning and maintenance	63
Cleaning	63
Disinfecting	63
Cleaning microphones	63
Batteries	64
AA Batteries (LR6 and HR6)	64
LBPBP1 and LBPHH1 Rechargeable Batteries	64
Important Notice	64
Warnings	64
First Use	65
Charging	65
Discharging	65
Battery Life	65
Disposal	65
Specifications	66
Accessories	67
Included accessories	67
N-DR1	67
N-BP1 (N-BP1-90 and N-BP1-03)	67
N-HH1-SL1	68
Options and spare parts	68
Specifications	70
N-DR1	70
N-BP1-90	70

N-BP1-03	71
N-HH1-SL1	71
Important safety instructions	72
N-DR1 N-Series Dual Channel Digital Wireless Receiver.....	72
N-BP1 (N-BP1-90, N-BP1-03) & N-HH1-SL1 N-Series Wireless Microphone Transmitters	73
Information on disposal	73
Information on disposal for users (private households)	73
Information on disposal for business users	74
Limited warranty	74
Important product information.....	75
Licensing information	75
Information to the user.....	75
USA and Canada.....	75
Region-dependent use of the wireless system	77
CE DECLARATION OF CONFORMITY.....	78
Contact, Service & Support	79
Europe	79
Americas.....	79

Introduction

The N-Series Digital Wireless Microphone System provides clear 24-bit audio quality with up to 126 dB dynamic range. The system supports AES-256 hardware encryption to provide a secure and private audio link between Transmitters and the Receiver. It provides a robust radio link, as well as true diversity and advanced audio codec, ensuring a stable connection between Transmitters and the Receiver.

A wide-band radio link (470 MHz to 870 MHz) makes it easy to find an available channel in even the most “crowded” environments. The Receiver offers an active loop through the antennas for daisy-chaining up to four units, providing an effortless way, together with a switched LAN connection, to set up a multichannel system. The standard connection supplies both switched and redundancy mode in selectable sample rates of 44.1 kHz, 48 kHz, 88.2 kHz and 96 kHz.

The optional analog audio output module supplies high-quality analog audio outputs.

Both handheld and bodypack Transmitters are available. Both types of Transmitters are designed to look slim and elegant yet are extremely robust, in lightweight metal casing, giving the best user experience.

The N-HH1-SL1 Handheld Transmitter is compatible with the DPA 2024-SL1 Supercardioid Vocal Mic, the DPA 2028-SL1 Supercardioid Vocal Mic as well as either of the d:facto® 4018 capsules (Linear or Softboost versions) with a SL1 adaptor. In addition, other brands of microphone capsules that can be used together with SL1 connections are supported.

The N-BP-90 Bodypack Transmitter is compatible with all DPA microphones with MicroLock® connectivity. The N-BP-03 Bodypack Transmitter is compatible with all DPA microphones with the LEMO 3-pin adapter but also supports most other brands using this type of connection.

The optional advanced lithium-ion rechargeable battery solution offers long operational time with a clear indication of battery lifetime as well as performance.

Each main component of the N-Series Digital Wireless System is described in this user guide.

Quick start guide

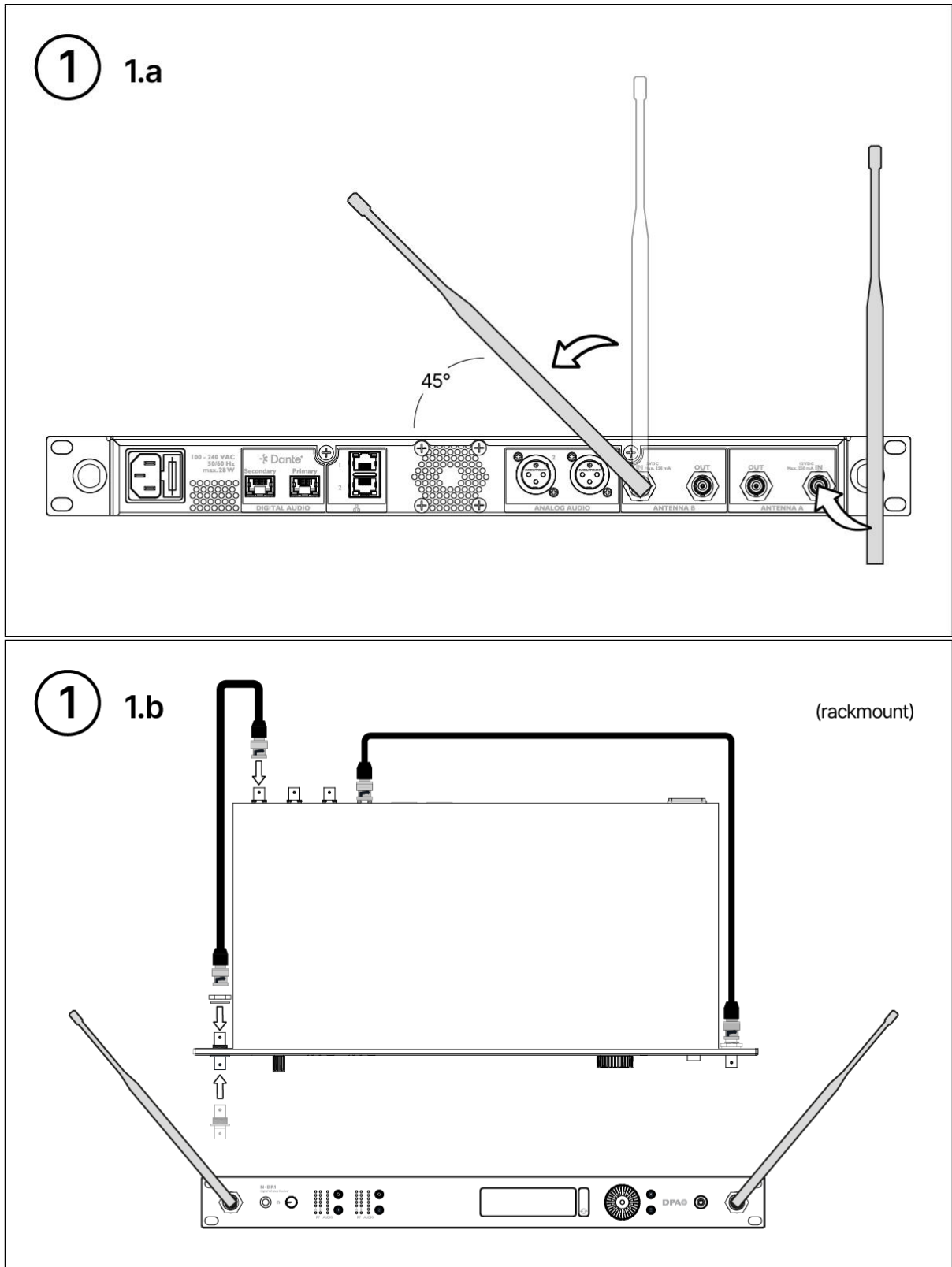

2 2.a

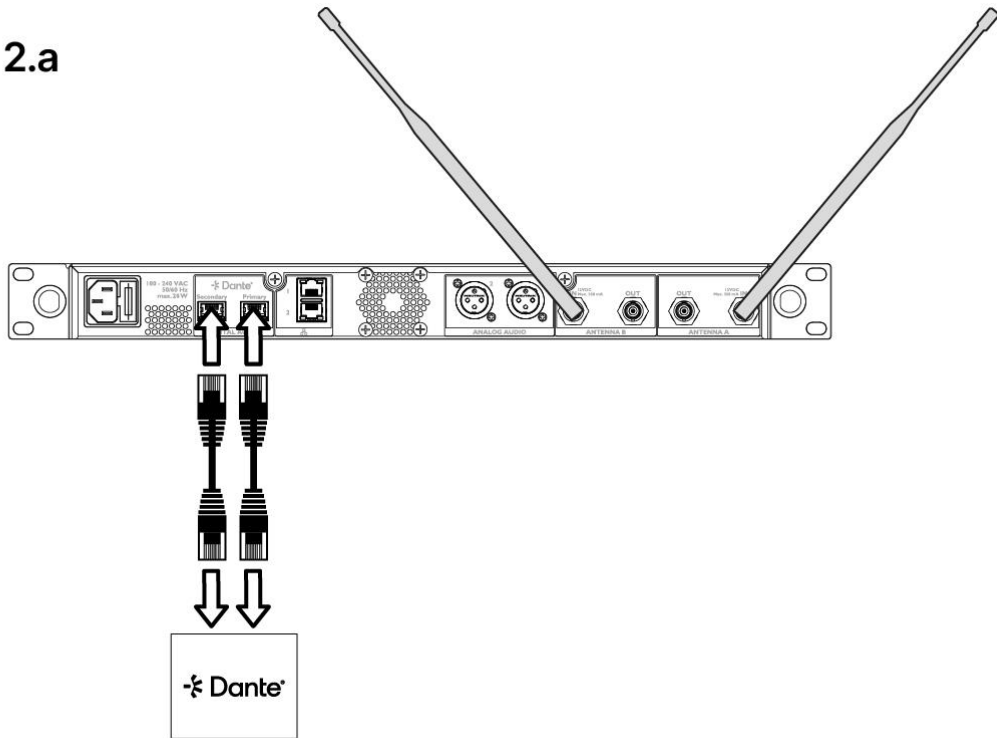

2 2.b Analog (optional)

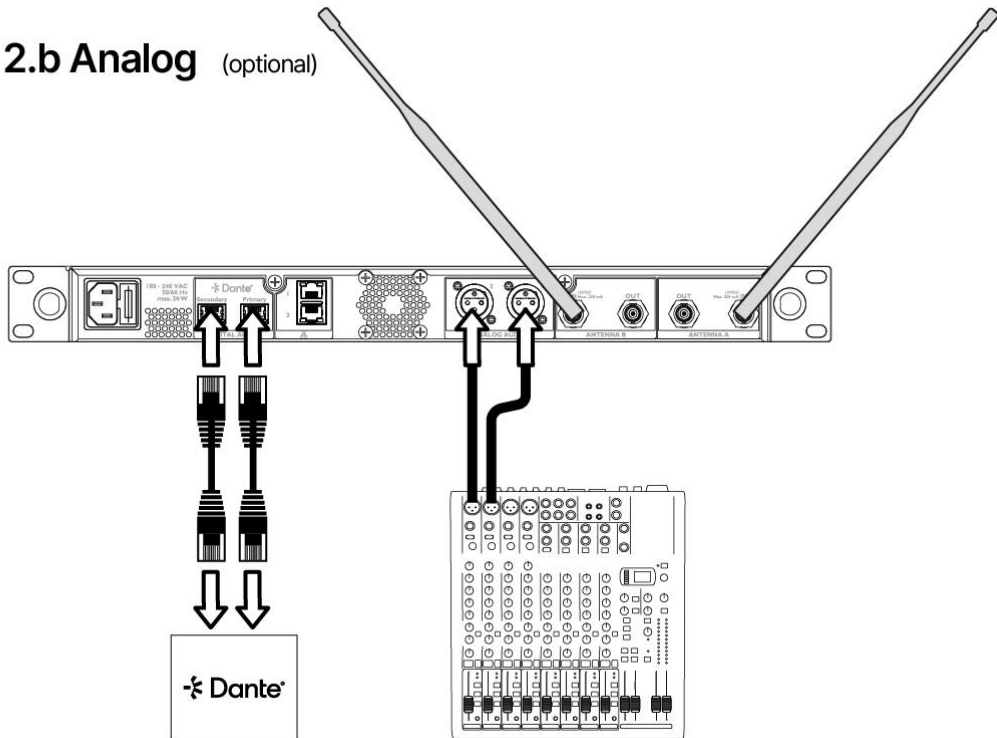

3 3.a

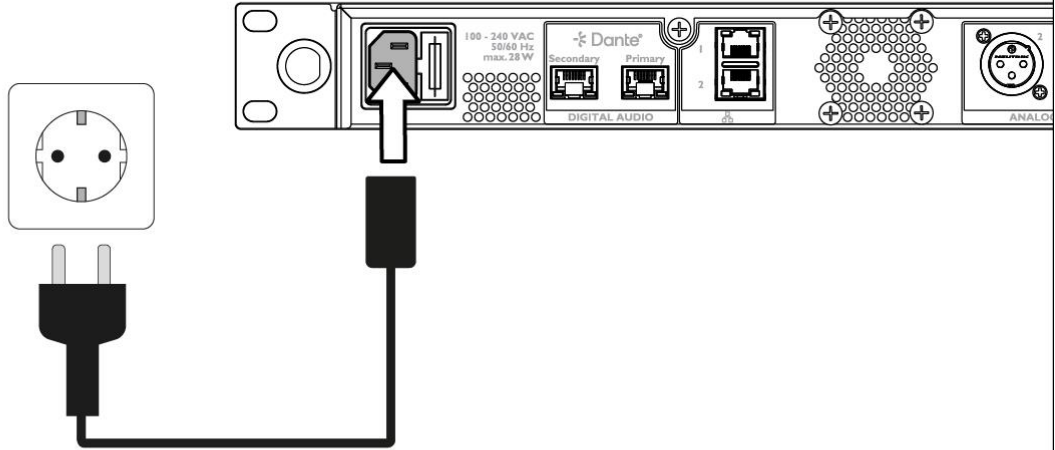

3 3.b

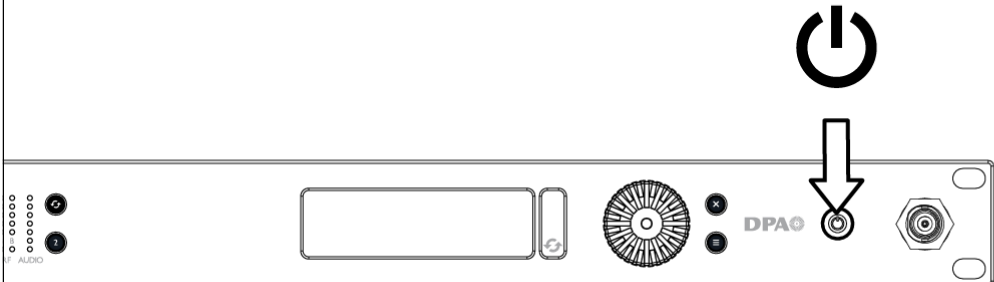

4 4.a

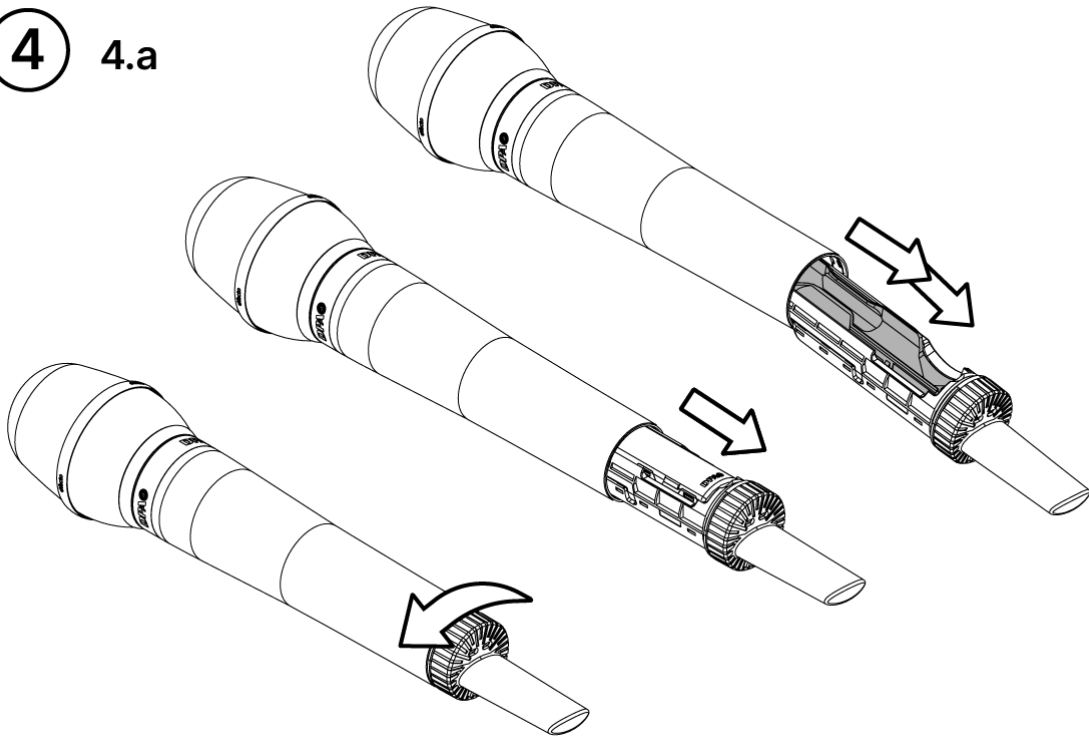

4 4.b

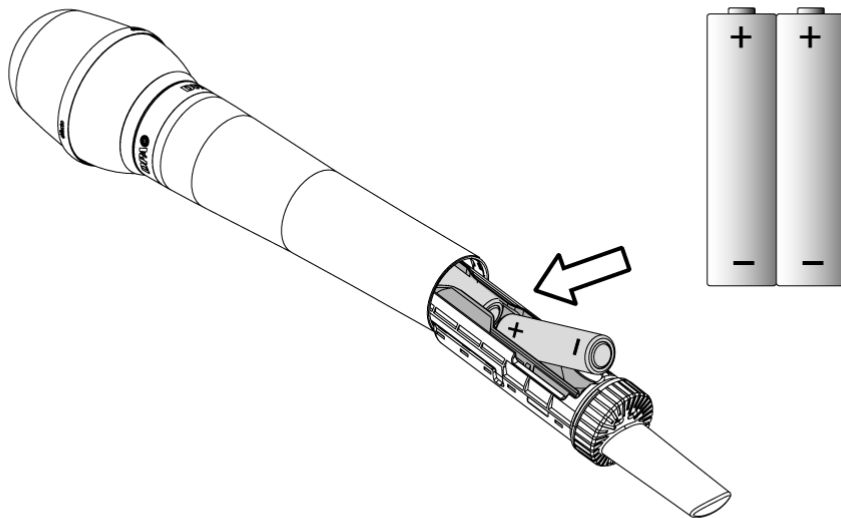

4 4.c

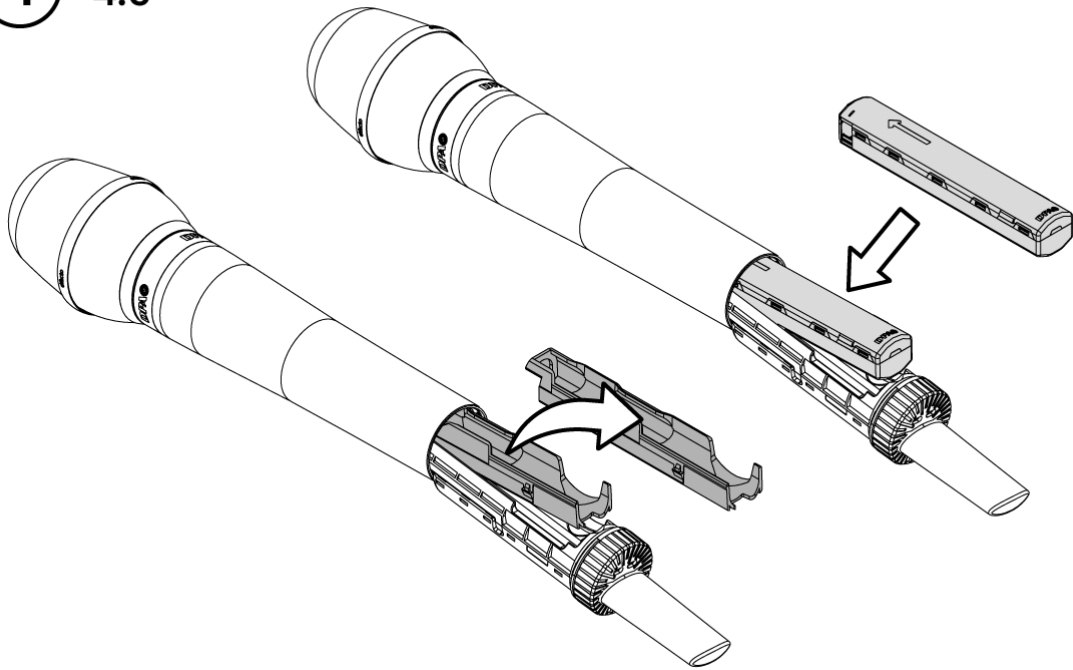

4 4.d

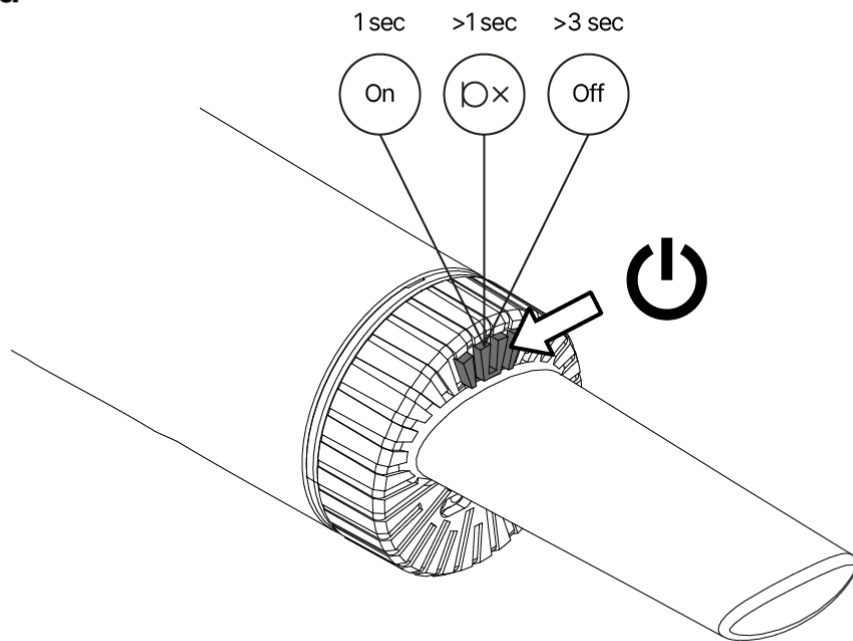

5 5.a

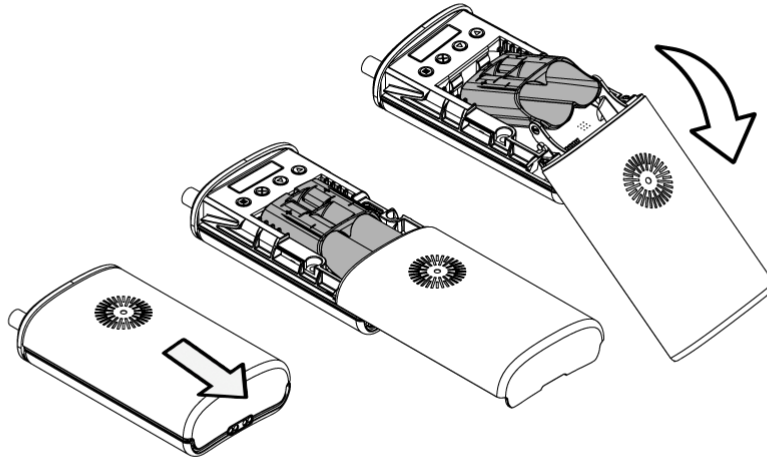

5 5.b

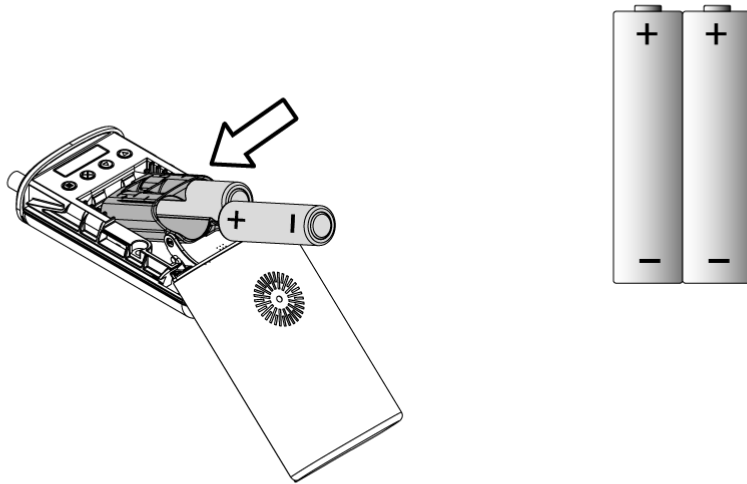

5 5.c

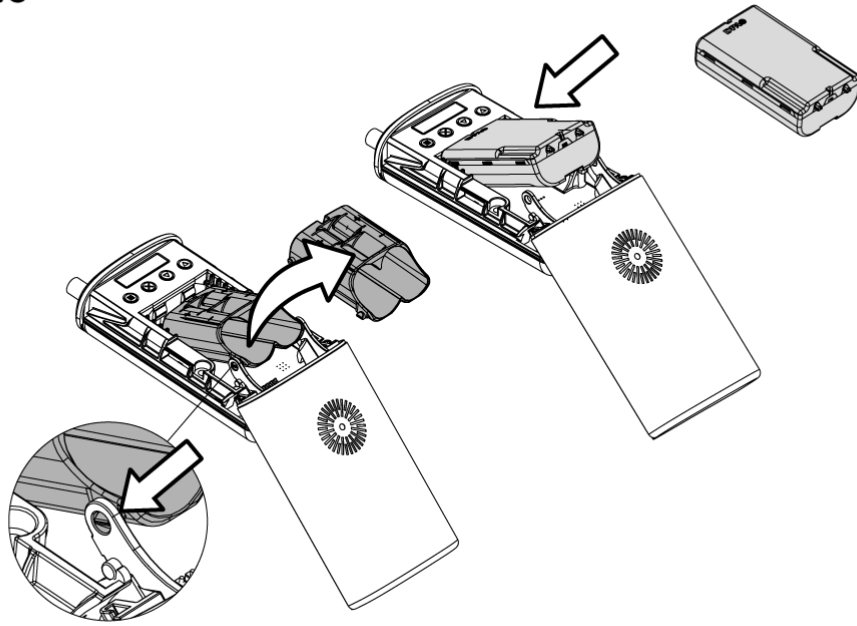

5 5.d

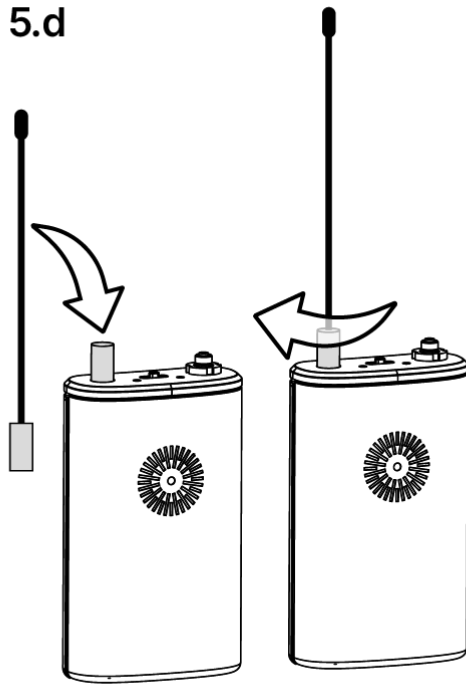

5.e

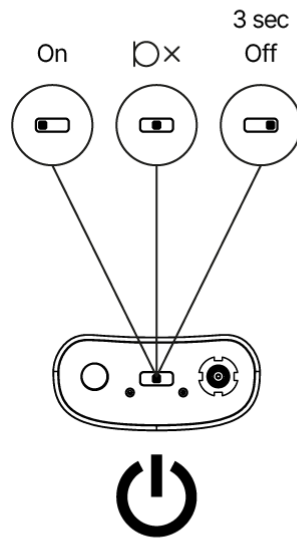

Getting started

This section shows you how to physically set up the system elements and how to establish the basic, starting functions, including tuning the system and synchronizing Transmitters.

Tuning the system

When turning on the Receiver for the first time, you must select the region the device is operating in. This is to ensure that the system works within a valid frequency range and Transmitter power for your region.

- The system will not work if there is any mismatch between the Receiver and the Transmitter
- Selecting a region/region which does not correspond to the region the system is being operated within may violate the law
- Even if the region setting is in accordance with the region that the system is being operated in, make sure that the selected frequency is valid
- Regional rules regarding valid frequencies and Transmitter power may occur within a region
- Make sure to acquire any licensing if required
- Contact local authorities regarding valid frequencies, Transmitter power and licensing
- Make sure to always run the latest Firmware to ensure that the system is using the latest radio settings for your region
- DPA Microphones is not responsible for any misuse of the system due to incorrect radio settings

IMPORTANT! Make sure that the selected or calculated frequency is valid in the region the equipment is being operated in. Always consult local authorities regarding valid frequencies, Transmitter power and if a license is required.

The system can be tuned in different ways. The easiest way is to use the QUICK SETUP function.

It is also possible to select a frequency from predefined groups of channels (frequencies) or to manually select a frequency within the range of the Receiver.

Note: It is important that all the Receivers are set to the same region and that they are all working in the same group of channels if predefined groups and channels are used.

Performing a QUICK SETUP

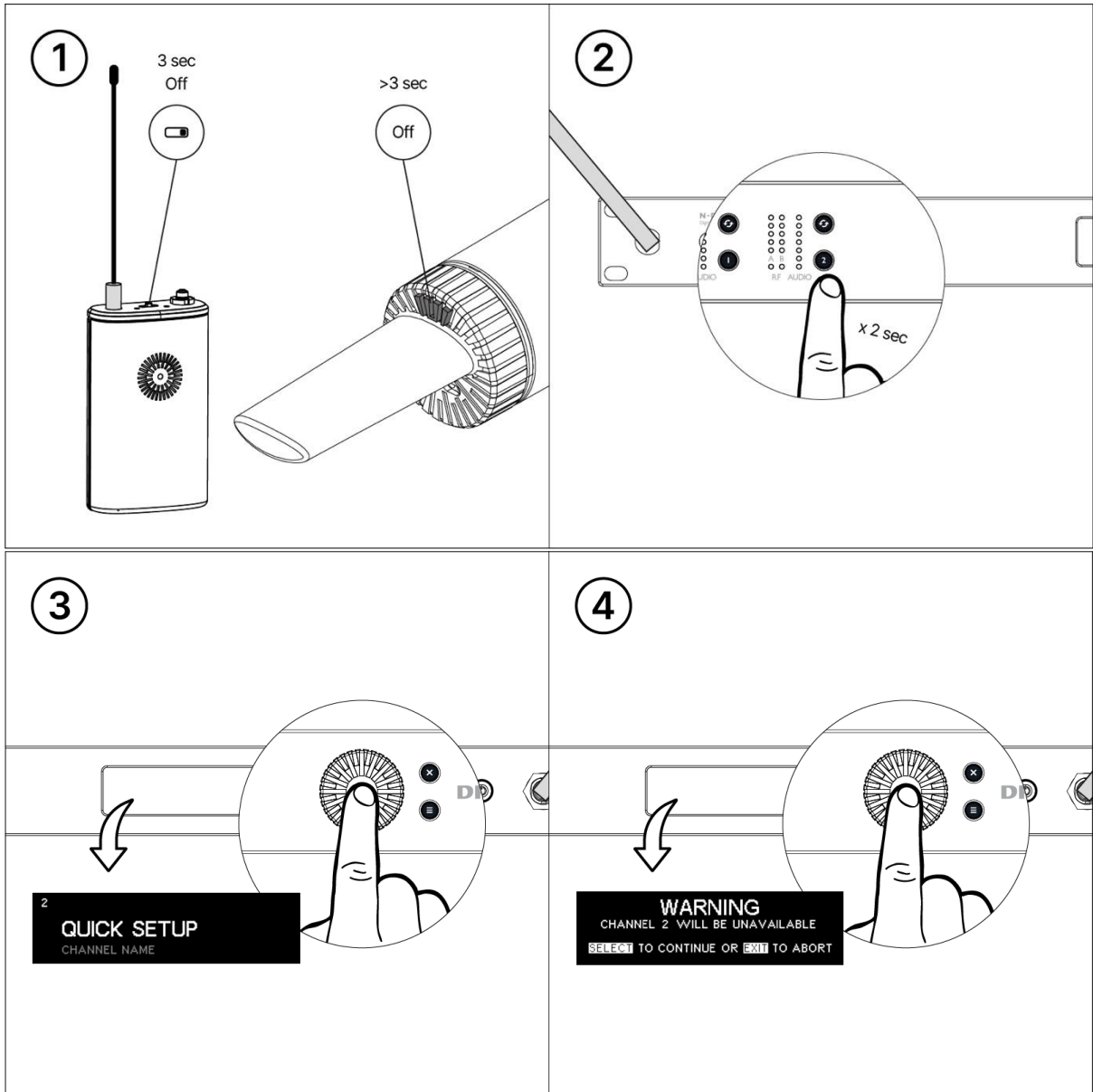

5 5.a

2 / QUICK SETUP
GROUP: 01

5.b

2 / QUICK SETUP
SCANNING

6 6.a

On

1 sec

On

6.b

2 / QUICK SETUP
FREQUENCY FOUND
GROUP: 01 CHANNEL: 01 - 470.100MHz
SELECT TO SYNC TX OR EXIT TO ABORT

SYNCHRONIZING

10 - 15 cm
(3.9 - 5.9 in)

7

2 / QUICK SETUP
TX2 SYNC DONE
EXIT TO RETURN TO MAIN MENU

1. Make sure all wireless Transmitters are turned off.
2. Push the Channel Select Button for 2 seconds to enter the Channel Menu.
3. Press the Navigation Wheel to start QUICK SETUP.
4. Press the Navigation Wheel again to accept that the wireless channel will be reconfigured.
5. Select the group of frequency channels to perform the setup within and press the Navigation Wheel to start.
6. When done, the selected frequency information is presented on screen. Turn on the selected Transmitter and hold its IR Sync Window in front of the IR Sync Window on the Receiver and press the Navigation Wheel to confirm the frequency and start the synchronization of the Transmitter.
7. When the synchronization is finished, the tuning of the wireless channel is done.

If no free channel is located, try again with another group of channels.

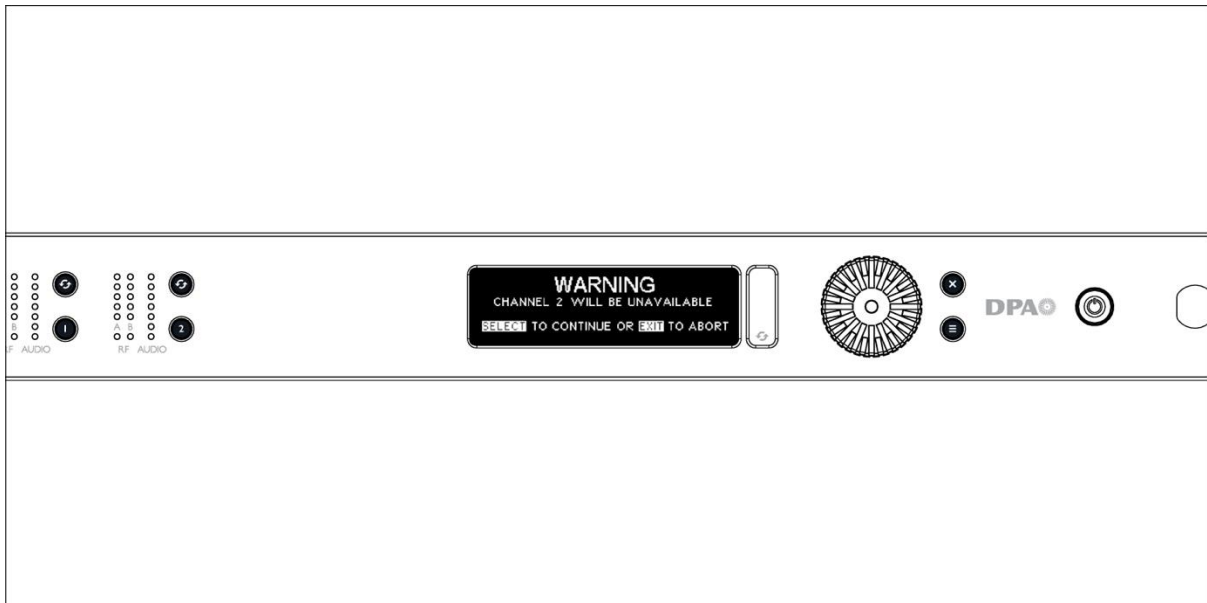

When more than one wireless channel is being tuned, previously tuned Transmitters should be left on while running *QUICK SETUP* on the rest of the channels.

Performing manual set up of group and channels

It is possible to configure the frequency group and channel manually. This is done in the Channel Menu for the selected channel under the Menu Point *RADIO – PRESET*.

Remember to either sync the Transmitter to the Receiver or set the same group and channel information on the Transmitter.

It is possible to select between three different groups:

Group 1

All channels are spaced equally with a space of 500 kHz.

Group 1 does not consider any form of intermodulation disturbance. It is therefore important to make sure that all Transmitters are kept at a minimum distance of 5 meters to the antenna and are transmitting with the same RF power.

Group 2

Channels are calculated from the lowest frequency and up and consider the disturbance 3rd order intermodulation can introduce.

Group 3

Same as Group 2, but the channels are calculated from the highest available frequency and down.

Performing manual set up of frequency

It is possible to select a specific frequency in steps of 25 kHz. This is done on the Channel Menu for the selected channel. In the RADIO menu, select the MANUAL mode and adjust the frequency. It is only possible to select a frequency valid for the region you are operating in.

Make sure that the regional setting is correct and that you are following any local restrictions that may apply.

Remember to either sync the Transmitter to the Receiver or set the same frequency information on the Transmitter.

Synchronizing a Transmitter

A Transmitter is synchronized with the Receiver via infrared (IR) communication.

The IR Sync Window on the Transmitters is located inside the device. Please see the relevant section for your Transmitter regarding the placement of the IR Sync Window.

As default, all Transmitter settings are mirrored in the Receiver and will be sent to the Transmitter when synchronized. If *Keep Transmitter Settings* is enabled, only settings relevant to transmission (Frequency and Transmitter Power) will be synchronized. All other settings will be ignored.

Starting the synchronization

Synchronization is started by holding the Transmitter's IR Sync Window approximately 10-15 cm (3.9-5.9 in) from the IR Sync Window on the front of the Receiver.

N-DR1 Digital Dual Channel Receiver

Included in the box

- N-DR1, Digital Dual Channel Receiver
- Mains power cord, 2 meters. The type of mains plug depends on the region
- 2 antenna cables, 50 Ω
- 2 antennas, 470 MHz to 1 GHz
- 2 BNC to BNC adapters for antenna mounting on front panel
- 2 hole covers for front panel antenna holes
- Quick Start Guide
- Important Safety & Warranty Information

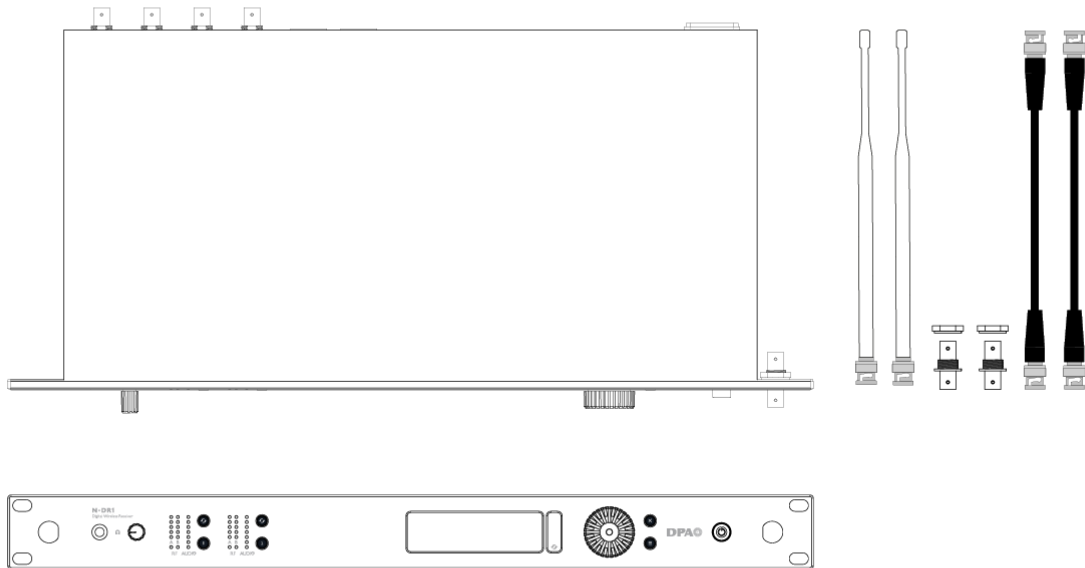

Hardware overview

Key features:

- Dante® Switched and Redundancy modes
- Headphone Output with mode switching and volume control
- Audio Level Meter with overload indicator
- Antenna Inputs with power for active antennas and active loop through
- Antenna Strength Indicators for each antenna on each channel with active antenna and overload indicator
- IR Sync Window for easy synchronization of Transmitters
- Open protocol for easy control of the unit via LAN (TCP or UDP)

Front panel view

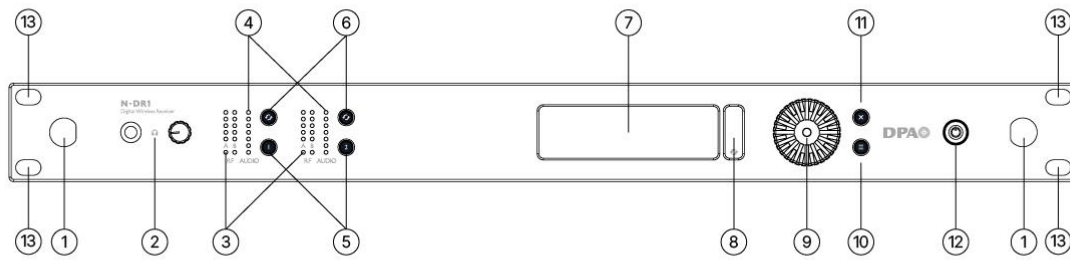

1. Mounting Holes for antennas
Used for mounting the Antennas or connecting Antenna Cables when the Receiver is mounted in a 19" rack or flight case
2. Headphone Jack Connector and Level Control Knob
3. Antenna Strength Meters with overload and active antenna indicators
4. Audio Meters showing the output level of the Receiver with overload indicators
5. Channel Select Buttons
6. Transmitter Synchronization Buttons
7. Display for channel information and menu system
8. IR Sync Window for Transmitter synchronization
9. Navigation Wheel with push-to-select functionality
10. Systems Menu Button
11. Exit Button
12. Power Button
13. Rack mounting holes

Back panel view

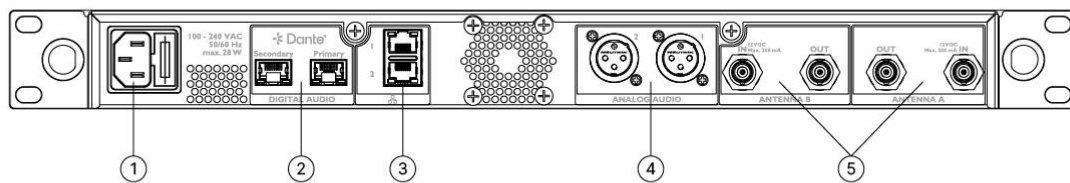

1. IEC Mains Power Socket
2. Dante Primary and Secondary Connections
3. Switched LAN Connections for control via TCP and UDP
4. Analog Audio Out (Optional)
5. Antenna A and B Connections with selectable power for active antennas and active loop through for daisy chaining Receivers

Installation

When installing the Receiver in a rack, please ensure that the chassis and cables are well supported. As the system dissipates up to 28 W, please ensure adequate space around the unit, especially when multiple units are installed in close proximity. It is recommended to add a 1 U perforated rack plate for every 4 Receivers in a stack. The Receiver has a built-in thermometer and will shut down if the temperature exceeds the maximum recommended level.

Note: Actual temperature can be read via the DPA Audio Controller Software. An indication of high or critical temperature will also be indicated on the front panel display of the Receiver.

Do not cover any vent holes on the sides or back of the Receiver when installing it in a rack or other enclosure.

Connect the power cord to an appropriate outlet including Mains Ground for maximum protection. The built-in power supply works from 100 – 240 volt (AC) and at both 50 and 60 Hz. It automatically adjusts to the supplied voltage.

The supplied whip type omnidirectional antennas must be mounted either directly on the back of the Receiver via the antenna input connectors or on the front panel via the supplied cables and BNC male/male chassis connectors. Avoid installing the antennas in a closed rack or metal structure as this will severely reduce the Receiver's ability to pick up Transmitter signals.

Note: Only enable antenna power when using active antennas. Some passive antennas may be recognized as a DC shortage and will shut down the antenna input.

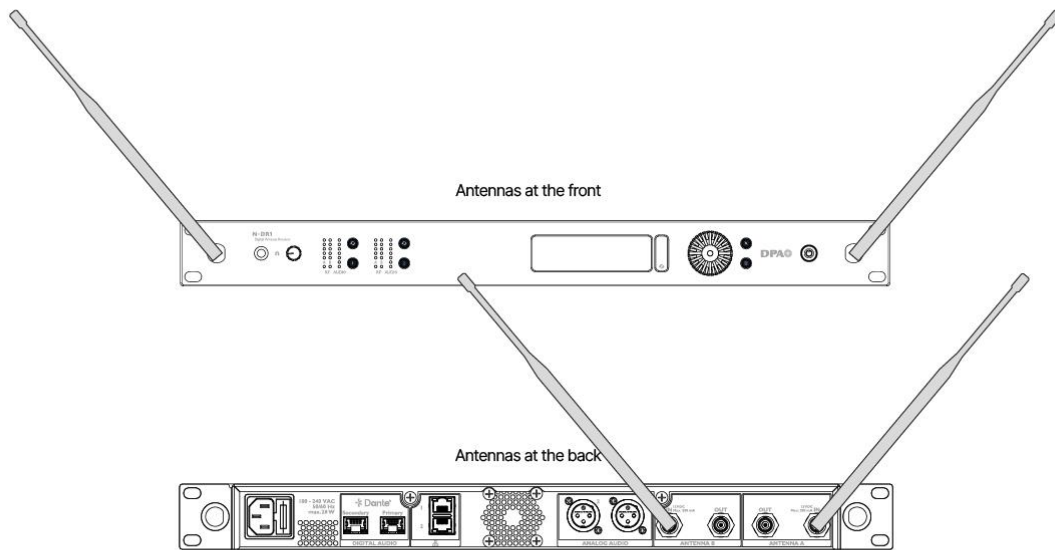

When multiple Receivers are mounted in a rack, the antenna loops can be used to daisy chain a pair of antennas to several Receivers.

Note: Do not daisy chain more than 4 Receivers to one antenna pair. When more Receivers are connected to the same set of antennas, please use an appropriate antenna distribution unit.

The Receiver has two sets of RJ45 Connectors. One pair is the Dante® Digital Audio Output that can be used in a true redundant set-up. Please refer to the section regarding [Networking and Dante®](#) for more details. The other set of RJ45 Connectors are for control and monitoring purposes via the DPA Audio Controller Software or other 3rd party software communication with the Receiver. The Receiver has a built-in switch allowing for daisy chaining of control signals.

Antenna cables

It is important to select the right Antenna Cables to optimize the loss between the antenna and the Receiver.

A loss greater than 6 dB in should be avoided and may jeopardize the RF performance of the system. On the other hand, a loss may be needed to avoid saturation of the RF input stage.

See the table below for the maximum length of different types of cables.

Type	Loss dB/meter @ 400 MHz	Loss dB/meter @ 700 MHz	Recommended maximum length
RG58/RG223	0.38 dB	0.56 dB	10-15 m (30-49 ft)
RG8	0.25 dB	0.31 dB	20-24 m (65-78 ft)

RG213	0.14 dB	0.22 dB	27-42 m (88-137 ft)
-------	---------	---------	---------------------

The values in this table are standard from Belden Cables.

Make sure to check the datasheet of the type of cable you are using for correct calculation of the loss.

It is also important to select a cable with good shielding. For example, RG58 and RG223 have the same loss in the cable, but the RG223 is better shielded and may therefore provide a better signal for the Receiver.

Operation

Main and detailed screens

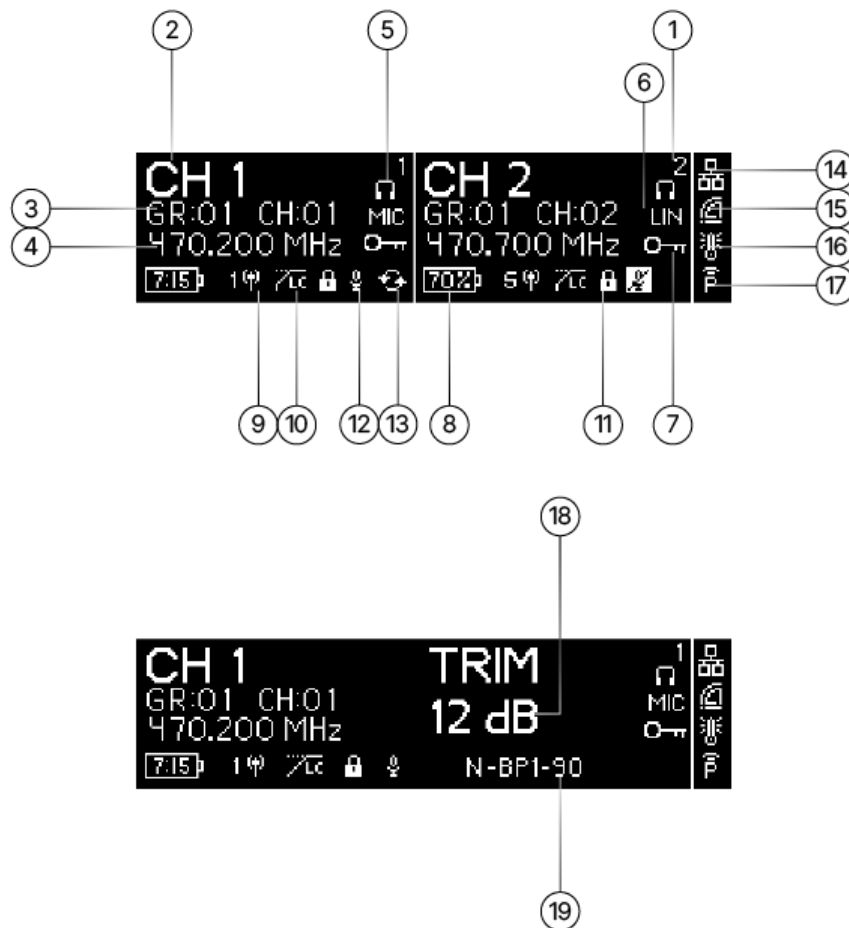

1. Wireless Channel Number
2. Wireless Channel Name
3. Selected Group and Channel
4. Selected Frequency
5. Headphone Selection Indication
6. Analog Output Mode (Line or Microphone)
7. Encryption enabled
8. Transmitter Battery Level

9. Transmitter RF Power
10. Low-Cut Filter enabled
11. Function Button Lock enabled
12. Transmitter Microphone Mute state
13. Sync mismatch between Transmitter and Receiver
14. Network connected
15. Dante® connected
16. Critical temperature warning
17. Antenna Power selected
18. TRIM
19. Transmitter Model

Menu system

How to enter and navigate the menu system.

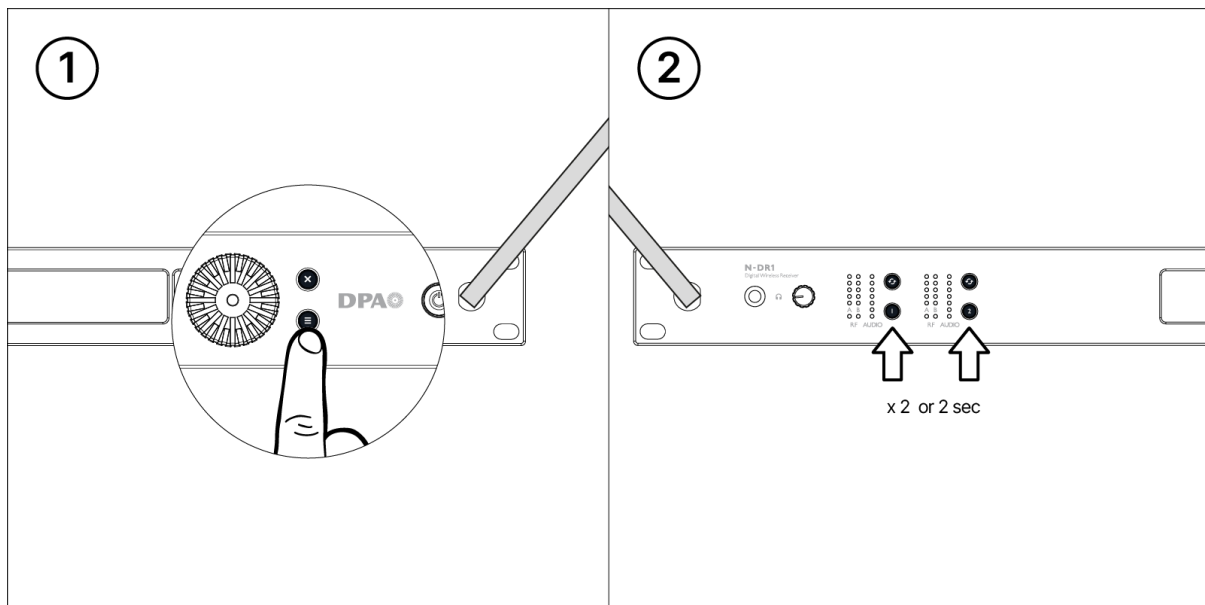

1. To enter the Receiver's Main Menu, press the Menu button found at the bottom right of the Navigation Wheel.
2. To enter the Channel Menu, press the Channel Selection button of the desired Channel twice or hold the button down for 2 seconds.

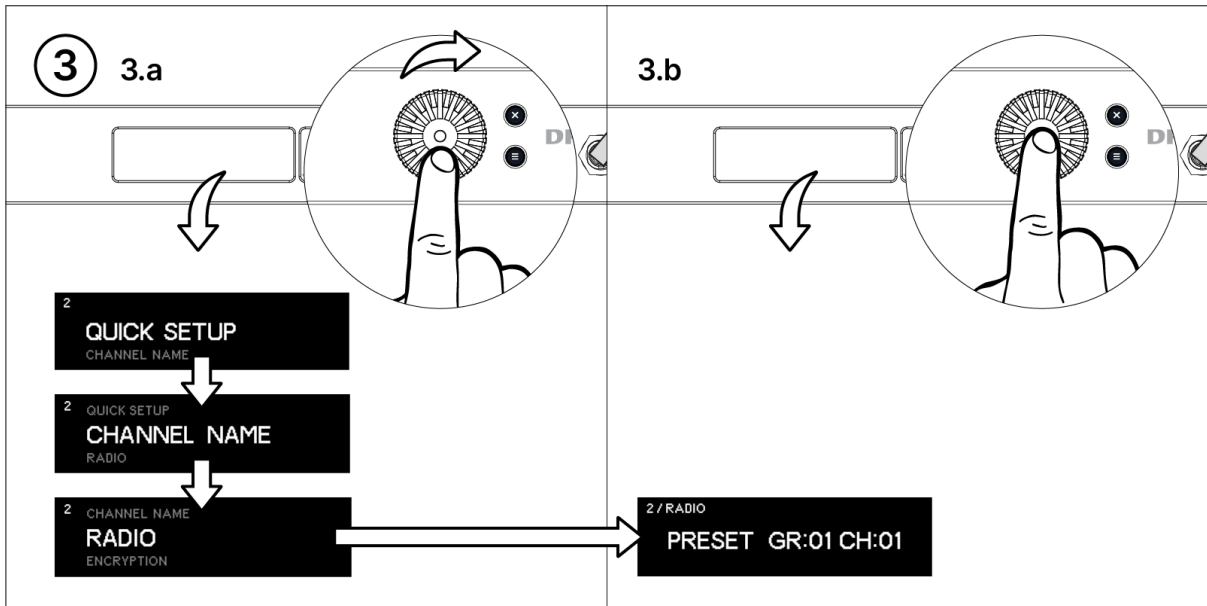

(The first time the button is pressed, a detailed view of the Channel will be shown with the possibility to adjust output level via the Navigation Wheel.)

- Turn the Navigation Wheel [3.a] to scroll to the desired menu item and press it to select [3.b] the desired function. (When navigating a Menu, it is possible to see the previous and next Menu Points above and below the selected one.)

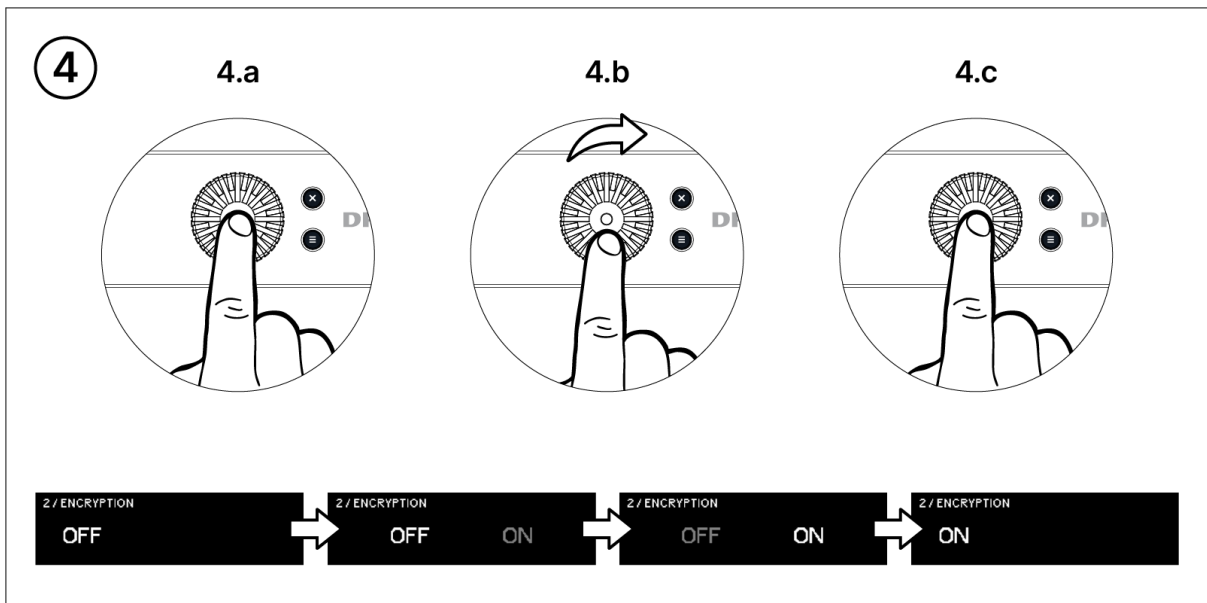

- To change a parameter, press the Navigation Wheel to highlight the value [4.a] and turn the Navigation Wheel to change the parameter [4.b]. When the desired value is located press the Navigation Wheel to save the changes [4.c].



5. To increase/decrease a number, turn the Navigation Wheel to select the value and press the Navigation Wheel to select it.

The parameter being changed is highlighted. Other values are grey.

An upward arrow above the parameter indicates that it is possible to increase. A downward arrow below the parameter indicates that it is possible to decrease.

Main menu

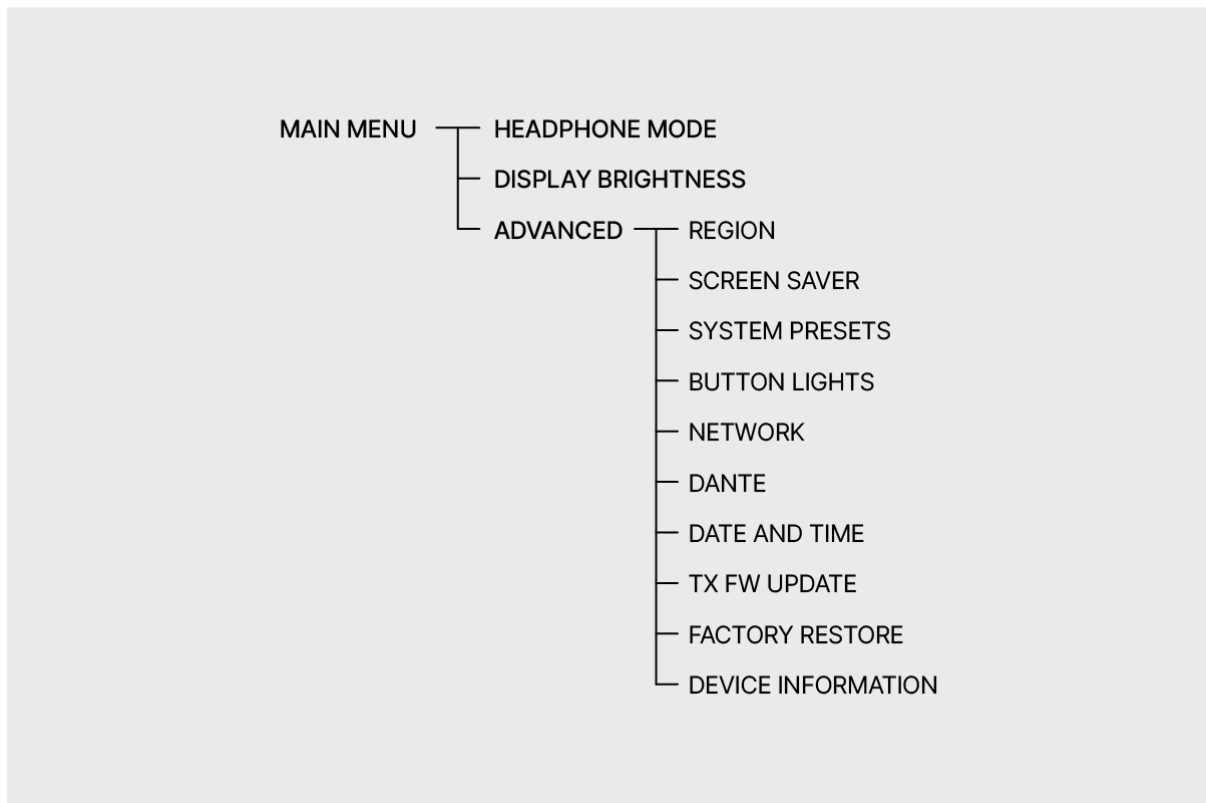

The Main Menu is entered by pressing the Menu Button on the right side of the Navigation Wheel.

This menu contains all settings related to the system, e.g., network settings, display settings, factory reset, etc.

Functions and settings

Headphone mode

(MAIN MENU → HEADPHONE MODE)

Selection of channels routed to the headphone output.

Possible values:

- **CH 1** Channel 1 only
- **CH 2** Channel 2 only
- **CH 1+2** Sum of Channel 1 and 2 (Default)

It is also possible to toggle the mode by pressing the Level Control Knob. The first press shows the current state. The 2nd press toggles the selection. The selection shows on the Display and disappears after 10 seconds of inactivity. The Display returns to the screen shown before the Headphone Button was pressed.

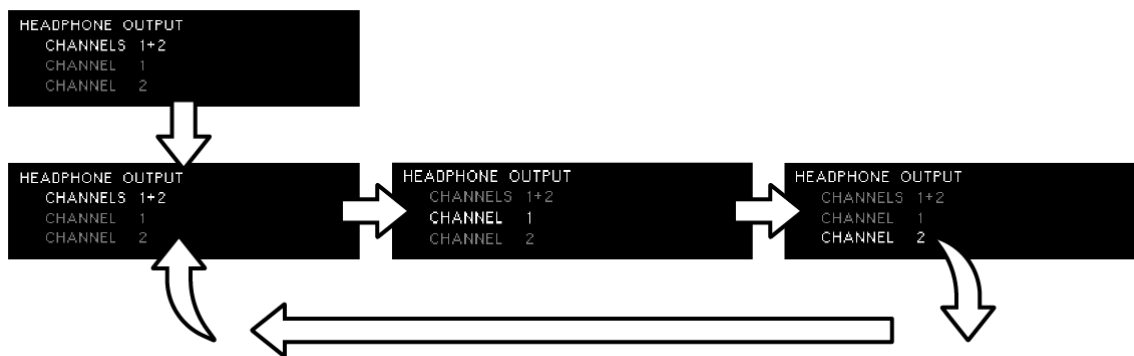

It is also possible to see the mode directly on the home screen of the Display. If a Channel is selected to the headphone output, then it is indicated with the  icon on the home screen and the detailed channel view.



Display brightness

(MAIN MENU → DISPLAY BRIGHTNESS)

Adjust the brightness of the display. It can be set between 30% and 100%.

- **75%** (Default)

Advanced

(MAIN MENU → ADVANCED)

Contains more advanced system settings/functions.

Region

(MAIN MENU → ADVANCED → REGION)

Select the Region in which the system is being used.

IMPORTANT! This is the first thing that is set up when the system is turned on for the first time. The system will not work if the region is not set.

Set the region to where the system is being used to avoid any legal issues. The selected region will affect the frequency ranges and Transmitter power.

Sync the Transmitter(s) after changing any of these settings. If the region settings are not that same between the Transmitter(s) and the Receiver, the system will not work. An alert  will show if there is a mismatch between the regions of the Transmitter(s) and Receiver.

Screen saver

(MAIN MENU → ADVANCED → SCREEN SAVER)

Enable a screen saver for the Receiver's Display. When turned on, the screen saver is activated after 15 seconds of disuse. Pressing any button on the front panel reactivates the screen.

Possible settings:

- **OFF** The Display is always lit (Default)
- **DARK** The Display turns dark (30%)
- **ON** The Display turns off

Antenna power

(MAIN MENU → ADVANCED → ANTENNA POWER)

Enable or disable the power for active antennas.

Possible settings:

- **ON**
- **OFF** (Default)

The maximum power is 12V/250mA.

If the antenna cable is shorted or the maximum power is exceeded, a warning will be shown on the Receiver's Display.



Note: Only enable antenna power when using active antennas. Some passive antennas may be recognized as a DC shortage and will shut down the antenna input.

System presets

(MAIN MENU → ADVANCED → SYSTEM PRESETS)

Allow all Systems Settings, including Channel Settings, to be saved in 1 of 5 presets.

Note: All settings in the Receiver will be changed when recalling a preset.

IMPORTANT! Remember to synchronize Transmitter(s) after recalling a preset.

Button Lights

(MAIN MENU → ADVANCED → BUTTON LIGHTS)

Set the button backlight and highlight intensity. Button backlight can be set between 0%-60%.

- **30%** (Default)

Highlight intensity can be set between 40%-100%.

- **100%** (Default)

Network

(MAIN MENU → ADVANCED → NETWORK)

Local area network (LAN) parameters.

Note: Changes to any network settings will be initialized when exiting the Network Menu.

Device name

(MAIN MENU → ADVANCED → NETWORK → DEVICE NAME)

Identifies the Receiver on the network (host name). Used to communicate with the unit over the network via the 3rd party protocol (OSC).

DHCP

(MAIN MENU → ADVANCED → NETWORK → DHCP)

Enable or disable DHCP for the network.

Possible settings:

- **ON** (Default)
- **OFF**

If DHCP is ON, it is not possible to change the IP address, subnet or gateway. If DHCP is OFF, it is necessary to manually type in an IP address, etc.

IP Address

(MAIN MENU → ADVANCED → NETWORK → IP ADDRESS)

If DHCP is ON, this menu will show the assigned IP Address. IF DHCP is OFF, it is possible to enter a valid IP address.

Subnet

(MAIN MENU → ADVANCED → NETWORK → SUBNET)

If DHCP is ON, this menu will show the assigned subnet mask. IF DHCP is OFF, then it is possible to enter a valid IP subnet mask.

Gateway

(MAIN MENU → ADVANCED → NETWORK → GATEWAY)

If DHCP is ON, this menu will show the assigned gateway. IF DHCP is OFF, it is possible to enter a valid gateway.

MAC address

(MAIN MENU → ADVANCED → NETWORK → MAC ADDRESS)

Show the LAN port's MAC address.

TCP control

(MAIN MENU → ADVANCED → NETWORK → TCP CONTROL)

Disable or enable control via 3rd party products like AV control systems etc.

Possible settings:

- **ON** (Default)
- **OFF**

TCP port

(MAIN MENU → ADVANCED → NETWORK → TCP PORT)

Set the port number that the TCP should listen to. Valid range: 100 to 65353.

- **1993** (Default)

UDP control

(MAIN MENU → ADVANCED → NETWORK → UDP CONTROL)

Disable or enable control via 3rd party products like AV control systems etc.

Possible settings:

- **ON** (Default)
- **OFF**

UDP port

(MAIN MENU → ADVANCED → NETWORK → UDP PORT)

Sets the port number that the TCP should listen to. Valid range: 100 to 65353.

- **1992** (Default)

Dante®

(MAIN MENU → ADVANCED → DANTE)

Change parameters and sub menus relating to Dante®.

Note: Changes to any settings will be initialized when exiting the Dante® Menu.
Any changes to Dante® settings will cause loss of audio.

Device name

(MAIN MENU → ADVANCED → DANTE → DEVICE NAME)

Set the device name used by the Dante controller. The maximum length of a name is 31 characters. See the rules for names in Audinate's Dante Controller User Guide.

Sample rate

(MAIN MENU → ADVANCED → DANTE → SAMPLE RATE)

Set the sample rate of the audio.

Possible settings:

- **44.1 kHz**
- **48 kHz** (Default)
- **88.2 kHz**
- **96 kHz**

Note: The system always samples the audio at 48 kHz. A sample rate converter is used to achieve other sample rates.

Mode

(MAIN MENU → ADVANCED → DANTE → MODE)

Set the mode.

Possible settings:

- **SWITCHED** (Default)
- **REDUNDANT**

When set to REDUNDANT, the device will duplicate audio traffic to both ethernet ports, allowing the implementation of a redundant network via the secondary port. When set to SWITCHED, the secondary ethernet port will behave as a standard switch port, allowing daisy chaining through the device.

Primary

(MAIN MENU → ADVANCED → DANTE → PRIMARY)

All settings about the primary ethernet port.

DHCP

(MAIN MENU → ADVANCED → DANTE → PRIMARY → DHCP)

Enable or disable DHCP for the primary network.

Possible settings:

- **ON** (Default)
- **OFF**

If DHCP is ON, it is not possible to change the IP address, subnet or gateway.

IP address

(MAIN MENU → ADVANCED → DANTE → PRIMARY → IP ADDRESS)

If Dante® primary DHCP is ON, this menu will show the assigned IP Address. IF DHCP is OFF, it is possible to enter a valid IP address.

Subnet

(MAIN MENU → ADVANCED → DANTE → PRIMARY → SUBNET)

If Dante® primary DHCP is ON, this menu will show the assigned subnet mask. IF DHCP is OFF, then it is possible to enter a valid IP subnet mask.

Gateway

(MAIN MENU → ADVANCED → DANTE → PRIMARY → GATEWAY)

If Dante® primary DHCP is ON, this menu will show the assigned gateway. If DHCP is OFF, it is possible to enter a valid gateway.

MAC address

(MAIN MENU → ADVANCED → DANTE → PRIMARY → MAC ADDRESS)

Show the MAC address for the primary port.

Secondary

(MAIN MENU → ADVANCED → DANTE → SECONDARY)

All settings about the secondary ethernet port.

This sub menu is only visible if the Dante® Mode is set to REDUNDANT.

DHCP

(MAIN MENU → ADVANCED → DANTE → SECONDARY → DHCP)

Enable or disable DHCP for the secondary network.

Possible settings:

- **ON** (Default)
- **OFF**

If DHCP is ON, it is not possible to change IP address, subnet or gateway.

IP address

(MAIN MENU → ADVANCED → DANTE → SECONDARY → IP ADDRESS)

If Dante® secondary DHCP is ON, this menu will show the assigned IP Address. If DHCP is OFF, it is possible to enter a valid IP address.

Subnet

(MAIN MENU → ADVANCED → DANTE → SECONDARY → SUBNET)

If Dante® secondary DHCP is ON, this menu will show the assigned subnet mask. If DHCP is OFF, then it is possible to enter a valid IP subnet mask.

Gateway

(MAIN MENU → ADVANCED → DANTE → SECONDARY → GATEWAY)

If Dante® secondary DHCP is ON, this menu will show the assigned gateway. If DHCP is OFF, it is possible to enter a valid gateway.

MAC address

(MAIN MENU → ADVANCED → DANTE → SECONDARY → MAC ADDRESS)

Show the MAC address for the secondary port.

Date and time

(MAIN MENU → ADVANCED → DATE AND TIME)

Adjustment of date and time. Date and time are used for logging purposes.

Date

(MAIN MENU → ADVANCED → DATE AND TIME → DATE)

Change the date.

Date is only used in corporation with DPA Audio controller logging

Time

(MAIN MENU → ADVANCED → DATE AND TIME → TIME)

Change the time.

Time is only used in corporation with DPA Audio controller logging

Transmitter Firmware update

(MAIN MENU → ADVANCED → TX FW UPDATE)

Update the Firmware of the Transmitter via the IR Sync Window between the wireless Transmitter and the Receiver. The Receiver always contains the corresponding Firmware for a wireless Transmitter.

Hold the Transmitters IR Sync Window approximately 10-15 cm (4-6 in) from the Receivers IR Sync Window when starting the process.

The process can take up to 4 minutes.

Factory restore

(MAIN MENU → ADVANCED → FACTORY RESTORE)

Doing a FACTORY RESTORE re-establishes the Receiver to factory default settings for the installed Firmware version.

IMPORTANT! Doing a FACTORY RESTORE will erase ALL custom settings. After doing a FACTORY RESTORE the Transmitter(s) must be resynchronized to the Receiver.

Device information

(MAIN MENU → ADVANCED → DEVICE INFORMATION)

Contains information about the Receiver, such as device type number, serial number and Firmware version.

Channel Menu

To enter a Channel Menu, press the Channel Selection Button of the desired Channel twice or press and hold it for 2 seconds.

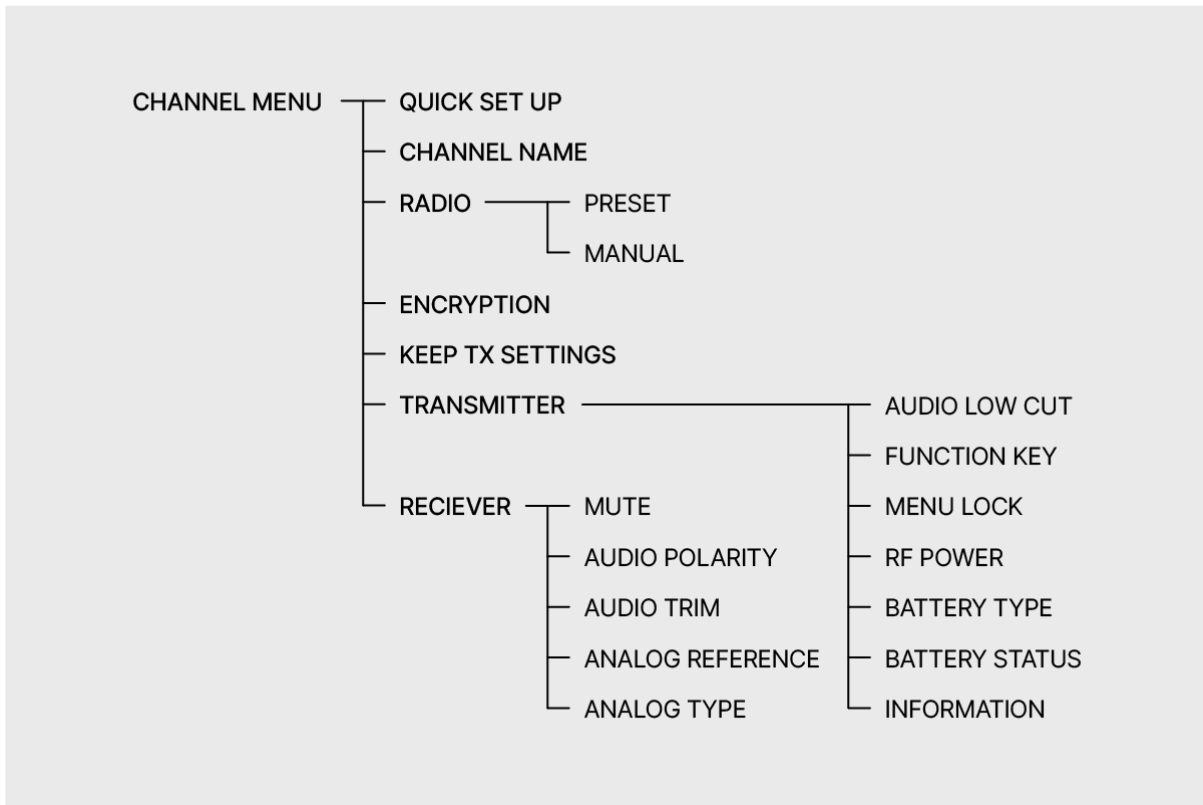

Functions and settings

QUICK SETUP

(CHANNEL MENU → QUICK SETUP)

QUICK SETUP is a fast and straightforward way to find a free frequency and save the frequency to the Transmitter.

See the chapter about [Tuning the system](#) for instructions on how to perform the QUICK SETUP.

Channel name

(CHANNEL MENU → CHANNEL NAME)

Each wireless channel can be given a name to make it easier to identify.

This name can consist of up to six characters. Use the Navigation Wheel to select each character. When the last character has been selected, the name will be saved and shown on the Display in the corresponding Channel section. If fewer than 6 characters are used, push the scroll wheel to save.



Note: The Transmitter must be synchronized to the Receiver for the changes to be finalized.

Radio

(CHANNEL MENU → RADIO)

It is possible to set/change the frequency that the wireless channel should use.

The frequency can be selected in two ways. Either via presets – chosen frequencies divided into groups and channels or manually.

When the preset option is selected, a group of channels is selected first and afterwards the channels. The frequency will be shown on the Display in the corresponding channel section.

When manually selected, the frequency is chosen in two parts. The high part in steps of 1 MHz and the low part in steps of 25 kHz.

IMPORTANT! It is only possible to select a frequency that corresponds to the region that the system is operated in. Make sure that the region setting of the Receiver is correct. If the setting is not correct, the system may not be compliant with local laws regarding radio transmissions.

Note: The Transmitter must be synchronized to the Receiver for the changes to be finalized.

Encryption

(CHANNEL MENU → ENCRYPTION)

It is possible to enable or disable AES-256 encryption for the selected wireless channel. Encryption is disabled by default.

Possible settings:

- **ON**
- **OFF** (Default)

Synchronize Transmitter(s) after changing the encryption setting.

Keep TX settings

(CHANNEL MENU → KEEP TX SETTINGS)

If KEEP TX SETTINGS is ON, only the frequency settings will be synchronized with the Transmitter.

If it is OFF, all Transmitter settings will be synchronized to the corresponding setting in the Receiver.

Possible settings:

- **ON**
- **OFF** (Default)

Transmitter settings

(CHANNEL MENU → TRANSMITTER)

The parameters/functions found in this sub menu relate to the Transmitter part of the Wireless Channel. The settings can also be adjusted directly on the Transmitter.

These settings will be included when synchronizing the Transmitter if the KEEP TX SETTING is OFF.

Sync the Transmitter after changing any of these settings in the Receiver.

- AUDIO LOW CUT
- FUNCTION KEY
- MENU LOCK
- RF POWER
- BATTERY TYPE
- BATTERY STATUS
- INFORMATION

Audio low-cut

(CHANNEL MENU → TRANSMITTER → AUDIO LOW CUT)

This setting enables or disables the analogue implemented 80Hz high pass filter (low-cut) in the microphone input stage on the Transmitter. Default is disabled.

Possible settings:

- **ON**

- **OFF** (Default)

Function key

(CHANNEL MENU → TRANSMITTER → FUNCTION KEY)

The Function Key (power button) on the Transmitter can work either as an audio mute (AF MUTE) or radio mute (RF MUTE) button, or it can be disabled to prevent a user from muting or turning off the Transmitter by mistake. When disabled, it will only work as a power button, enabling the user to turn on the Transmitter.

Possible settings:

- **AF MUTE** (Default)
- **RF MUTE**
- **OFF**

To turn off the Transmitter in this mode, remove the battery.

Menu lock

(CHANNEL MENU → TRANSMITTER → MENU LOCK)

This feature makes it possible to lock the four menu buttons on the Transmitter. This prevents the user from changing any settings on the Transmitter.

Holding the menu and the arrow up key for 3 seconds will unlock the menu. The menu will lock itself again after approximately 10 seconds.

Possible settings:

- **ON**
- **OFF** (Default)

RF Power

(CHANNEL MENU → TRANSMITTER → RF POWER)

It is possible to set the RF power of the Transmitter.

Possible settings:

- **Off** (Muting of the RF stage)
- **1 mW**
- **5 mW**
- **10 mW**
- **20 mW**

- **50 mW**

Note: Pressing the exit (X) button on the transmitter while powering the transmitter will disable the radio (RF MUTE). Restarting the transmitter will get it into normal operation mode.

Note: Due to local restrictions, only the valid RF levels for the selected region/frequency will be selectable.

Make sure that the region setting of the Receiver is correct. If the setting is not correct, then the system may not be compliant with the local laws regarding radio transmissions.

Battery Type

(CHANNEL MENU → TRANSMITTER → BATTERY TYPE)

It is possible to select the type of AA batteries inserted in the Transmitter.

Possible settings:

- Alkaline
- NIMH

This setting is used to calculate the remaining lifetime of the battery in percentage.

It is important to select the right battery type to get the best estimation of the remaining battery life.

If a DPA rechargeable battery is inserted in the Transmitter this setting is ignored.

Battery status

(CHANNEL MENU → TRANSMITTER → BATTERY STATUS)

Shows the battery usage status.

If AA batteries are used in the Transmitter, it will show the remaining battery lifetime in percentage.

If a DPA rechargeable battery is used in the Transmitter, it will show the following information:

Charge: Remaining lifetime of the battery in hours and seconds

Health: Overall health of the battery, estimated from the usage data of the battery

Cycles: Number of times the battery has been charged

Temperature: Internal temperature of the battery

Information (Tx)

(CHANNEL MENU → TRANSMITTER → INFORMATION)

This contains information about the Transmitter such as device type number, serial number and Firmware version.

Receiver

(CHANNEL MENU → RECEIVER)

The parameters/functions found in this submenu relate to the selected Channel in the Receiver.

No need for Transmitter synchronization when changing these settings.

Mute

(CHANNEL MENU → RECEIVER → MUTE)

Mute the audio output of the Receiver for the selected Channel. This affects all analog and digital outputs for the selected wireless Channel (not headphones).

Possible settings:

- **ON**
- **OFF** (Default)

Audio polarity

(CHANNEL MENU → RECEIVER → AUDIO POLARITY)

This function changes the polarity of the audio for the selected Channel. Default is POSITIVE, which means that the polarity of the audio is not changed. NEGATIVE changes the polarity of the audio signal.

Possible settings:

- **POSITIVE** (Default)
- **NEGATIVE**

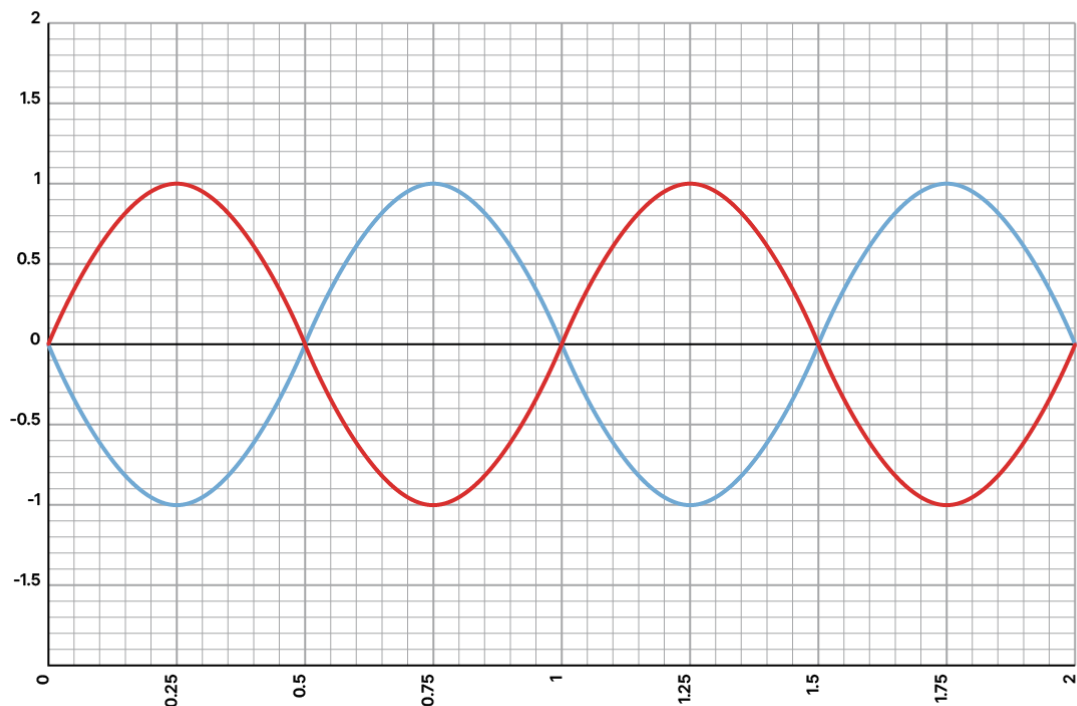

Note: Default value is positive, which matches all DPA mics. A positively increasing sound pressure produces positive going voltage on the output, as for example, on pin 2 (hot) of an analog XLR connector from the wireless system.

Red signal. *POSITIVE*. The original signal.
Blue signal. *NEGATIVE*. Polarity inverted.

Audio trim

(CHANNEL MENU → RECEIVER → AUDIO TRIM)

Adjust the trim of the audio signal of the selected wireless Channel. This is applied to both analog (if this option is installed) and digital audio. This is also applied to the audio meters so that the meters represent the output of the device.

This function is the same as the audio trim adjustment found on the detailed Channel View. The value can be set between 40 dB and -20 dB, regulated in steps of 1 dB. Default is 0 dB.



Note: There is no need to adjust the audio gain. The dynamic range of the wireless system is 126 dB. This adjustment of the trim is for the outputs NOT setting a gain for the microphones. See [Audio level and trim](#) for more details.

Analog reference

(CHANNEL MENU → RECEIVER → ANALOG REFERENCE)

This setting is only available if the analog audio option is installed.

Adjust the analog audio level (dBU) in relation to the digital level (0 dBFs). The ANALOG REFERENCE can be between 0 dBU and 20 dBU. The value can be regulated in steps of 1 dB. Default is 18 dBU.

Analog type

(CHANNEL MENU → RECEIVER → ANALOG TYPE)

This setting is only available when the analog audio output option is installed.

Possible settings:

Version: April 27, 2026

- **LINE** (Default)
- **MICROPHONE**

Link analog output type to either line or microphone level.

The microphone level is attenuated by 30 dB compared to the line level.

Audio level and trim

As stated above, the system has a very high dynamic range, i.e. a low noise floor and a high level before 1% THD meaning that the corresponding voltages from an attached microphone will always have a higher noise floor and a lower 1% THD level thus being within the window of wireless systems capabilities. For this reason, there is no need to set gain in the system as a gain will also amplify the self-noise of the connected microphone.

The only real need is therefore to set the (digital) trim level to balance the audio signals, if needed, so that the connected equipment downstream receives a trimmed signal.

A quick simplified overview of this digital trimming function can be found in the block diagram on the next page. Please note that the trimming function affects all the levels of the:

- Audio Level Meter
- Digital audio output via Dante
- Analog output on XLR (with analog ref. for full scale)
- Headphone Output

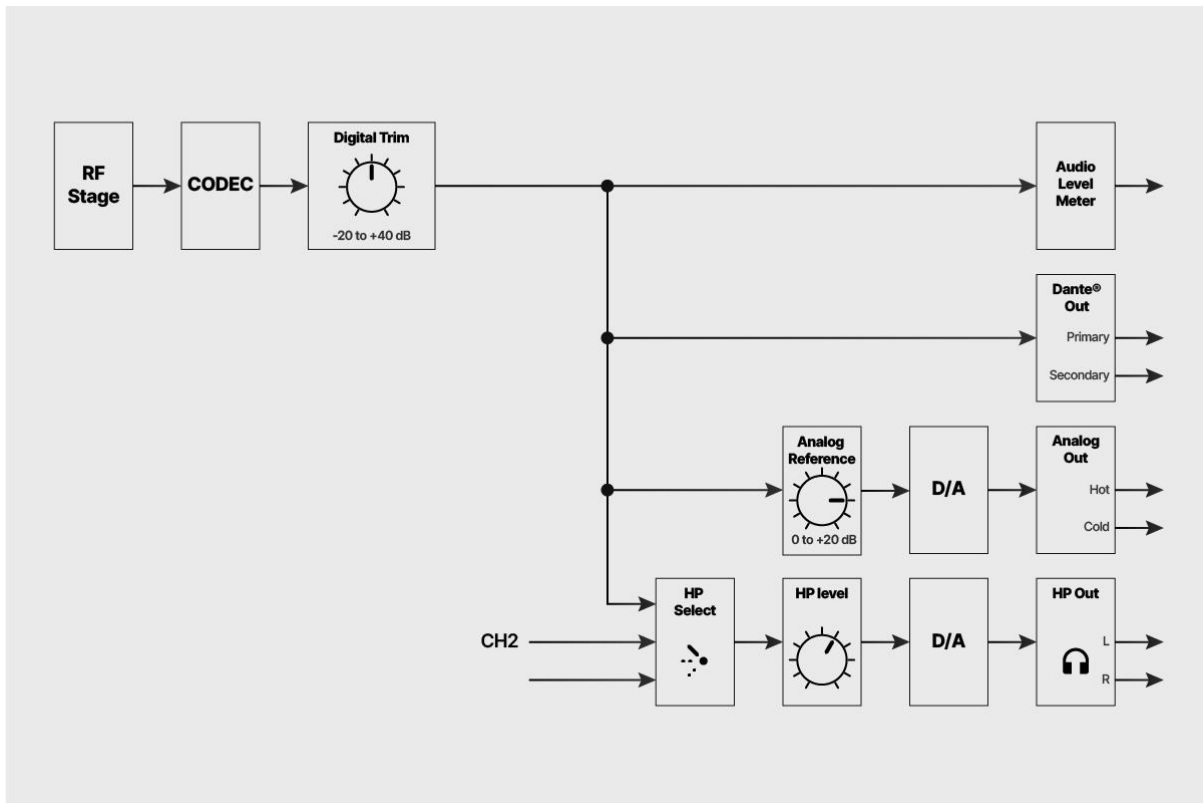

Trimming of the digital Receiver (one channel).

Networking and Dante®

The N-DR1 Receiver offers separate LAN interfaces for and Control.

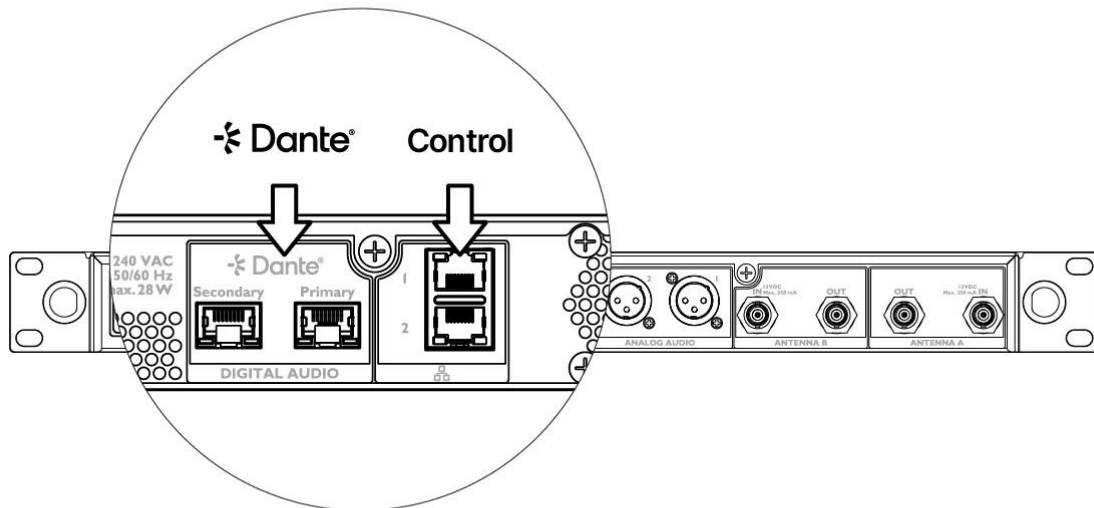

Control network

The control network offers methods for controlling the device over a local area network (LAN) from 3rd party control systems (Crestron, AMX, Extron and other brands).

The interface consists of two switched LAN ports for easy daisy chaining of devices to save ports in the local switch or router compared to a common star network configuration.

The illustration below shows the Receivers in a switch configuration.

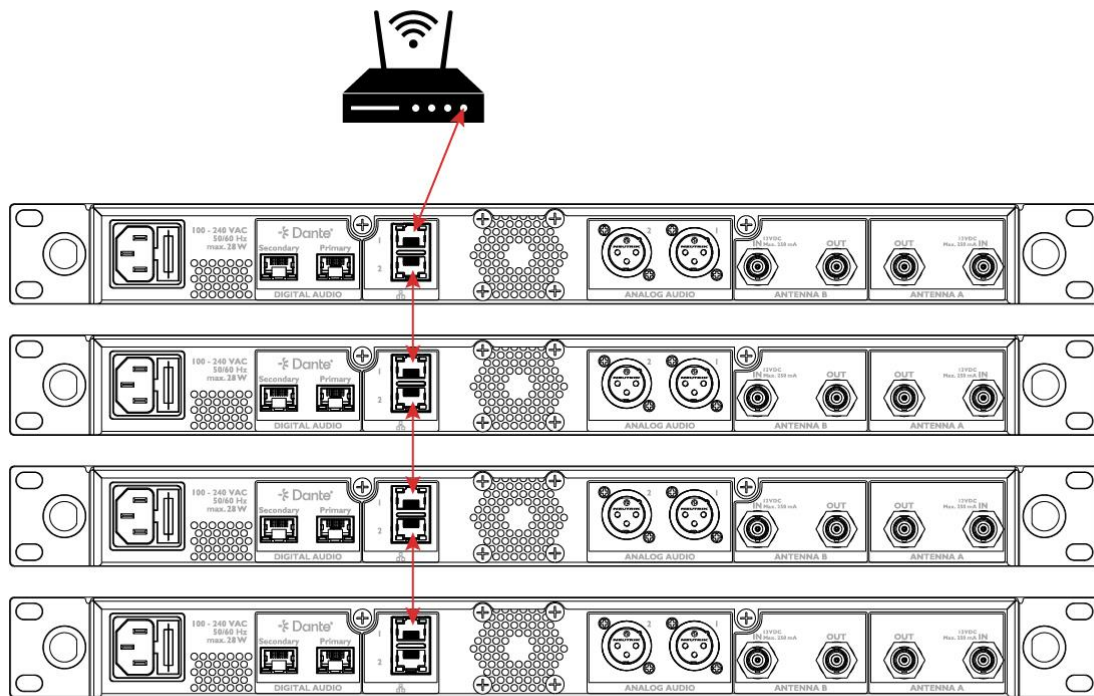

The illustration below shows the Receivers in a star network configuration.

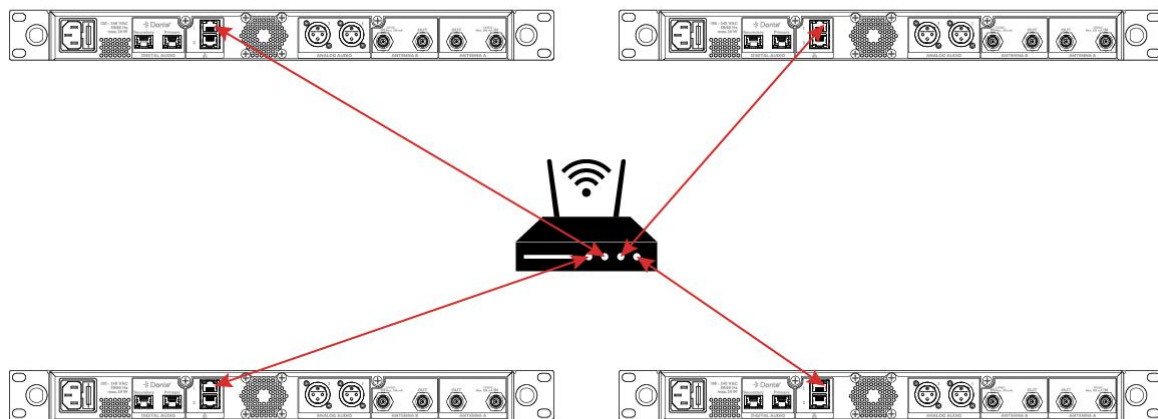

The protocol is based on the Open Sound Control protocol (OSC) and supports both TCP and UDP connections.

For further information about the OSC protocol and how to use it, consult the OSC Protocol Programmer Guide.

It is possible to disable or enable control via LAN from the Main Menu.

The Receiver is as default using TCP/IP port 1993 and UDP/IP port 1992. These can be changed in the Main Menu.

HDCP is enabled as default for the control interface, but can be disabled for manual configuration of IP address etc.

Note: Changes to any network settings will be initialized when exiting the Network Menu.

Connecting to an External Control System

It is possible to control and read out states via a 3rd party control system from manufacturers such as Crestron, AMX, Extron and others.

The control systems will be communicating with the Receiver via the OSC Protocol.

Please, refer to the OSC Protocol Programmer Guide for the chosen control system for more information about how to set up the connection and implementation of the OSC Interpreter.



The N-DR1 offers Dante® as its main audio output. Both Switched and Redundancy modes are supported, as well as sample rates 44.1 kHz, 48 kHz, 88.2 kHz and 96 kHz.

Use the Main Menu to configure the different modes, name, sample rate and settings related to the network.

Other Dante®-related settings and audio routing are configured via the Dante® Controller. Please, consult the Dante® Controller User Guide for more information.

Note: Cross-points must be set via the Dante® Controller before audio is transported from the N-DR1 Receiver. Updating the Dante® interface Firmware must be done via the Dante® controller. Please, consult the Dante® controller documentation about how to perform this procedure.

Note: The receiver will be shown with 4 channels in the Dante® Controller. Wireless channel 1 will be on Dante channel 1 and 2 and wireless channel 2 will be on channel 3 and 4.

Please, note that changes to any Dante® settings will be initialized when exiting the Dante® Menu. Changes to a Dante® setting will result in loss of audio.

Mixing and the control network

It may be necessary to mix (or combine) the Dante and the control network.

When doing this, make sure that the Dante® interface is in Switched mode and that the control interface is the last one in the chain.

Below is an example of a mixed network.

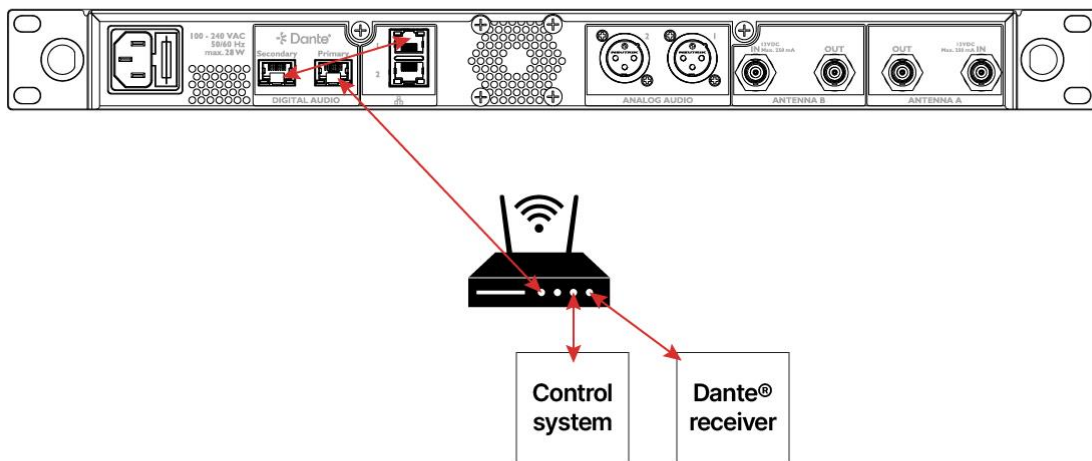

Do not mix the Dante® and the Control Network when using the redundancy Dante® mode.

DPA Audio Controller Software

This software offers an easy-to-use application for Windows and MacOS to control, monitor and set up single and multi-system setups.

DPA Audio Controller software is available from the DPA website at:

<https://www.dpamicrophones.com/wireless/n-series/>

For further information, please refer to the DPA Audio Controller User Manual.

Reading the meters

The front panel has two types of meters for easy indication of audio levels and radio strength.

Audio level

The audio meter consists of 7 LEDs where the top LED indicates audio clipping on the audio output of the Receiver for each wireless channel.

The values and color of each LED are illustrated below:

O	Red	-0.3dB
O	Yellow	-3dB
O	Yellow	-6dB
O	Green	-12dB
O	Green	-18dB
O	Green	-24dB
O	Green	-40dB

AUDIO

Radio strength

The radio strength meter indicates the strength of each antenna at the selected frequency for each Wireless Channel. Each meter consists of 5 LEDs for each antenna where the top LED indicates if the radio input stages are saturated.

A 6th LED indicates the active antenna the system has decided to use.

The values and color of each LED are illustrated below:

O	O	Red	-30dBm, Overload
O	O	White	-60dBm
O	O	White	-70dBm
O	O	White	-80dBm
O	O	White	-90dBm
A	B		
O	O	Yellow	Active Antenna indication

RF

N-BP1 (N-BP1-90 and N-BP1-03) Bodypack Transmitters

Included in the box

- 2 AA batteries
- 1 antenna
- Storage pouch
- Quick Start Guide
- Important Warranty and Safety Instructions

Hardware overview

Key features:

- 126 dB dynamic range
- Wide frequency range: from 470 MHz to 870 MHz
- 8+ hours of operation with standard AA batteries or DPA Rechargeable Battery Pack
- N-BP1-90 – compatible with DPA microphones with MicroLock® connectivity
- N-BP1-03 – LEMO for connection of microphones with 3-pin LEMO connector
- Lithium-ion rechargeable battery solution (optional)

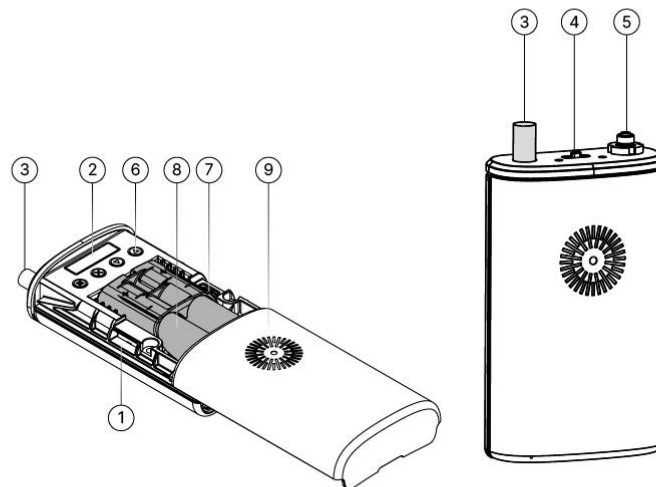

Bodypack Transmitter view

1. IR Sync Window for synchronization
2. Menu and Status Display
3. Antenna Connector
4. Programmable Function Button and power/mute LEDs
5. Microphone Connector. N-BP1-90 with DPA MicroLock® connector, N-BP1-03 with LEMO connector
6. Buttons for menu navigation

7. USB-C Connector for Firmware updates and maintenance
8. Battery Bay for DPA Lithium-Ion Rechargeable Battery or AA batteries mounted in detachable battery tray
9. Terminals for charging DPA Lithium-Ion Rechargeable Battery

Batteries

When using the N-BP1 with standard AA batteries then it is necessary to use the included battery tray. See illustration below for how to open and insert the batteries.



Caution: Risk of fire or explosion if the battery is replaced by an incorrect type. Only use LR6 or HR6 (AA) batteries. Always replace both batteries when changing the AA batteries.

Note: Both batteries should be inserted with the positive terminal towards the Display as shown on the battery tray.

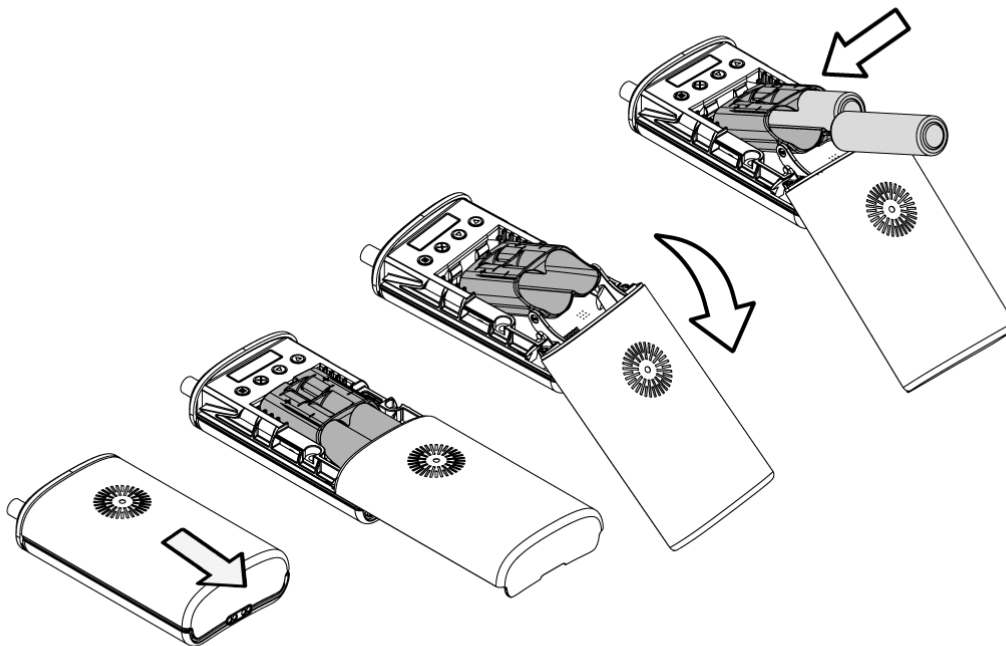

When used with AA batteries, the Transmitter will calculate the estimated remaining power in percentage. This information will be presented on the Display. If less than 15% power is left on the batteries, the power LED (green) on top of the unit will start flashing.

Connector types

The N-BP1 Bodypack comes in two variations of the audio connector – N-BP1-90 with a DPA MicroLock® Connector and N-BP1-03 with a 3-pin LEMO Connector.

Interface schematics

The interface schematics are as described below.

Insert schematics of input stages

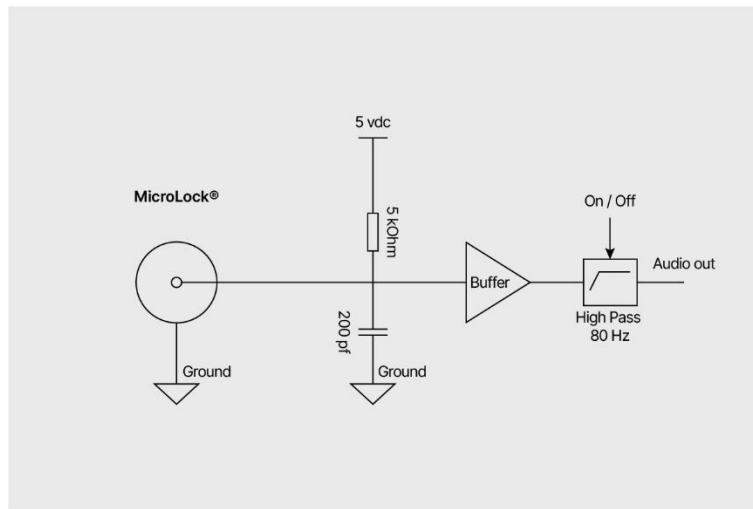

MicroLock®

The MicroLock® carries the signal on the center pin and ground on the shell.

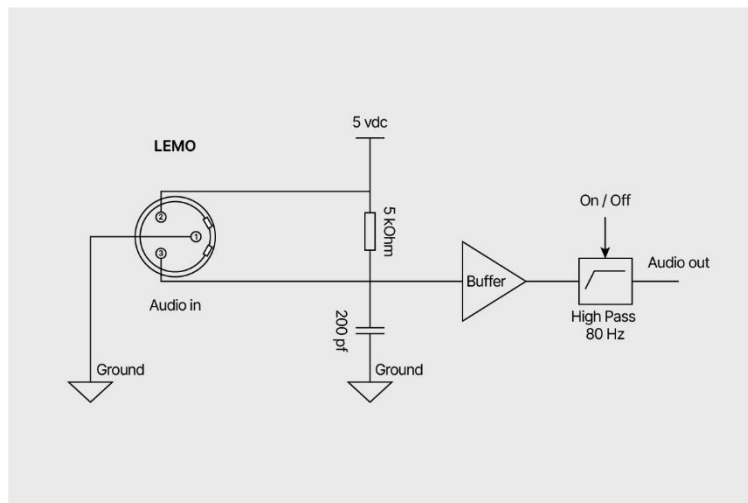

LEMO

The 3-pin LEMO Connector is terminated as:

Pin 1: Ground

Pin 2: Bias Voltage

Pin 3: Audio

Instrument cables

There are 4 types of cables available for the Bodypack transmitters. These all include an impedance converter inside the jack that has been carefully chosen to best convey the signal from the connected instrument to the bodypack.

There are two choices of Jack plugs, one with Rear cable exit (straight jack – Type R) and one with Side cable output (angled jack – Type S).

For the Bodypack part there are also two choices of input plugs, i.e. MicroLock (90) or LEMO 3-pin (03).

Please refer to this table for product identification:

CALR90	Instrument cable for N-BP1-90 with Jack Rear Output, MicroLock
CALR03	Instrument cable for N-BP1-03 with Jack Rear Output, 3-pin LEMO
CALS90	Instrument cable for N-BP1-90 with Jack Side Output, MicroLock
CALS03	Instrument cable for N-BP1-03 with Jack Side Output, 3-pin LEMO

N-HH1-SL1 Handheld Transmitter

Included in the box

- 2 AA batteries
- Clip for microphone stand mounting
- Storage pouch
- Quick Start Guide
- Important Warranty and Safety Instructions

Hardware overview

Key features:

- 126 dB dynamic range
- Wide frequency range: from 470 MHz to 870 MHz
- Compatible with standard AA batteries
- SL1 connectivity supporting a wide range of microphone cartridges
- Lithium-ion Rechargeable Battery solution (optional)

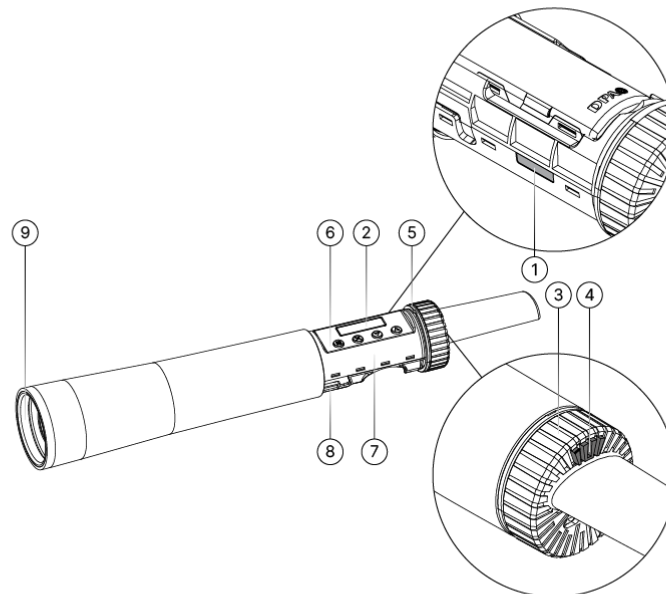

Handheld Transmitter view

1. IR Sync Window for synchronization
2. Menu and Status Display
3. Terminals for charging DPA Lithium-Ion Rechargeable Battery
4. Programmable Function Button and power/mute LEDs

5. Changeable color rings for easy identification (optional)
6. Buttons for menu navigation
7. Battery Bay for DPA Lithium-Ion Rechargeable Battery or AA batteries mounted in detachable Battery Tray
8. USB-C Connector for Firmware updates and maintenance
9. SL1 microphone cartridge connectivity

Batteries

When using the N-HH1-SL1 with standard AA batteries, the included battery tray must be used. See illustration below for how to open and insert the batteries.



Caution: Risk of fire or explosion if the battery is replaced by an incorrect type. Only use LR6 or HR6 (AA) batteries. Always replace both batteries when changing the AA batteries.

Note: Both batteries insert with the positive terminal towards the microphone as shown on the Battery Tray.

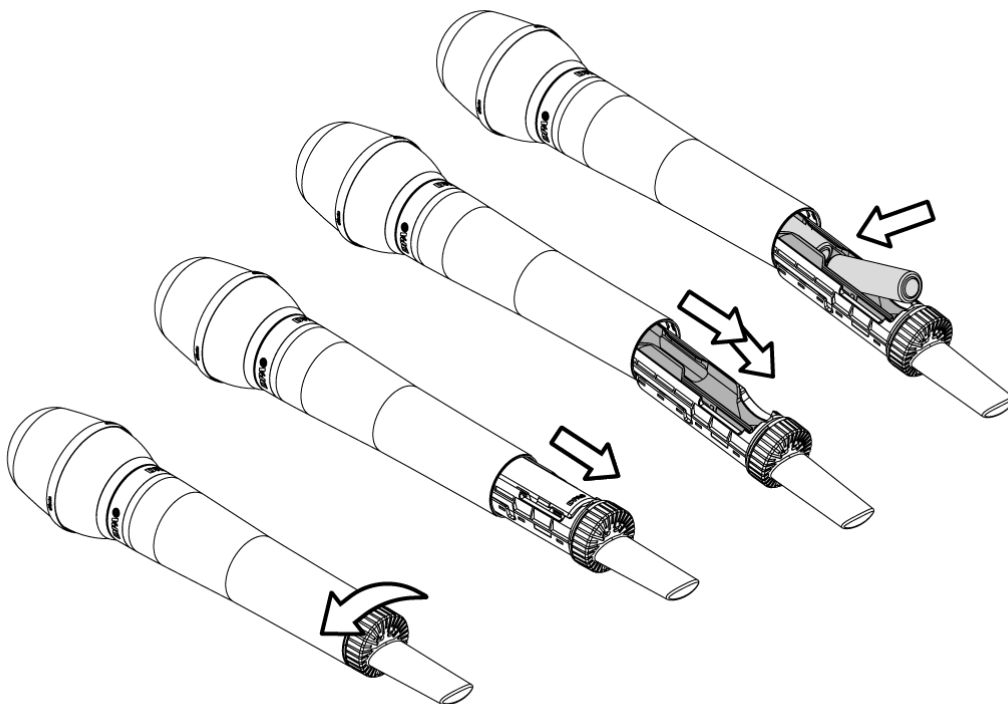

When used with AA batteries, the Transmitter will calculate the estimated remaining power in percentage. This information will be presented on the Display. If less than 15% power is left on the battery, the power LED (green) on top of the unit will start flashing.

Changing the identification ring

The optional colored identification rings, IDR0001, can be installed simply by opening the handle as shown in the figure below. Gently pull the standard black ring towards the battery compartment, using a fingernail to get it free from its position and remove the ring from the Transmitter.

The decided new colored ring is installed in the opposite direction, i.e. opening the ring, so it can slide over the battery compartment and rotate it, so that the gap in the ring is positioned at the corresponding spot on the Transmitter. Slide the ring to the right position and it will lock into place. Close the Transmitter once completed.

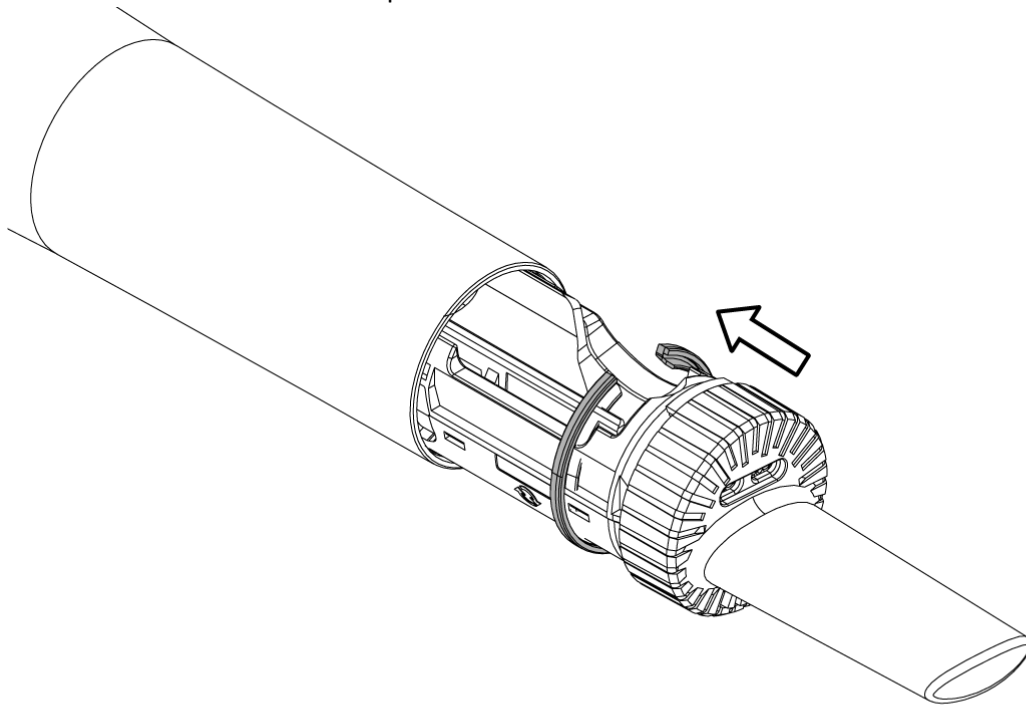

Operating Transmitters

Powering on and off, and muting the Transmitter

The Function Button is used to control the mute and power state of the Transmitter.

The button can be disabled via the menu system to prevent unintentional use. The button can only be used to turn on the Transmitter. To turn off the Transmitter, remove the batteries.

On the handheld Transmitter the Function Button is located at the end of the Transmitter next to the antenna between the mute and the power indicators.

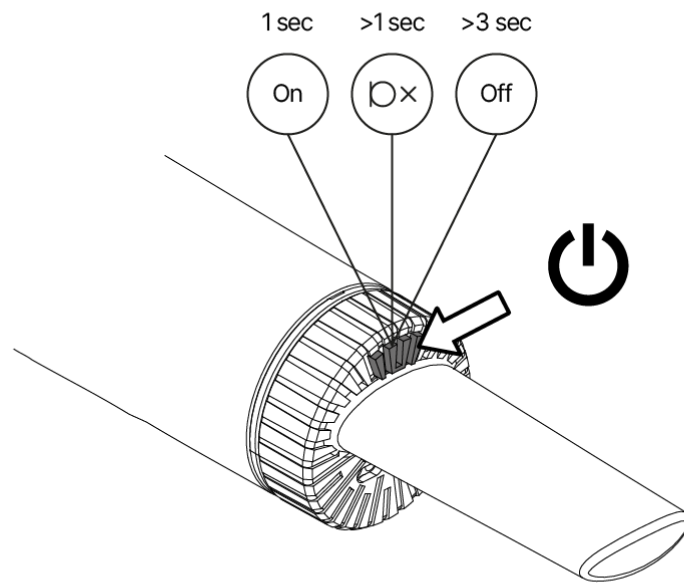

Press and hold the Function Button for about 1 second to power on the Transmitter. This will be indicated with a green light to the right of the button.

To turn off the Transmitter press and hold the button for 3 seconds. A countdown timer will be shown on the Menu Display.

To mute the Transmitter, press and hold the Function Button for 1 second until a red light to the left of the button indicates that the Transmitter is muted.

On the Bodypack Transmitter, the Function Button is a sliding switch, which is placed on top of the unit between the mute and the power indicators.

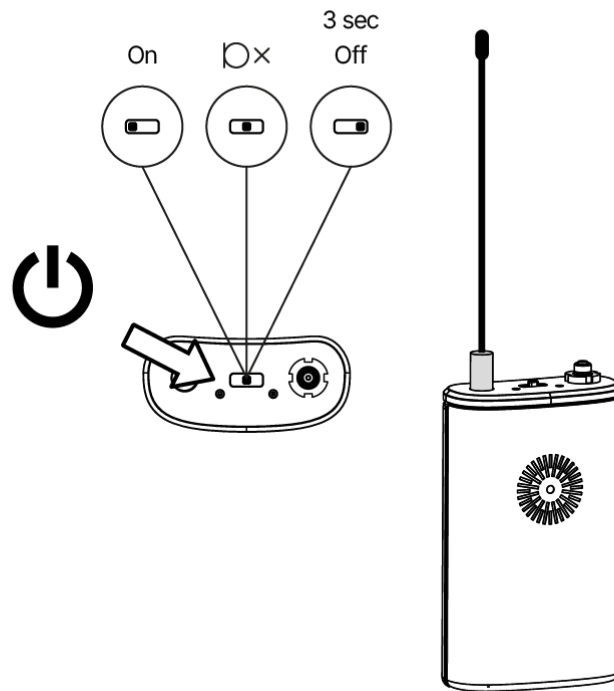

Slide the switch to the ON side to power on the Transmitter. This will be indicated with a green light.

Slide and hold the Function Button for 3 seconds toward the OFF position to turn off the Transmitter. A countdown timer will be shown in the Menu Display.

To mute the Transmitter, place the switch in the center position. This will be indicated with a red light.

The power indicator (Green LED) indicates that the Transmitter is on.

If the battery has less than 15% of its capacity left, then the power indicator will start flashing.

Main screens

The transmitters have 4 different main screens displaying different information for the user:



Screen 1:

- Wireless Channel name
- Selected Frequency
- Menu Lock indication
- Remaining lifetime in percentage or time dependent on the type of battery



Screen 2:

- Wireless Channel name
- Selected Group/Channel preset
- Menu Lock indication
- Remaining lifetime in percentage or time dependent on the type of battery

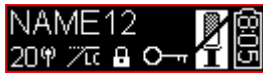

Screen 3:

- Wireless Channel name
- RF Power setting
- Low Cut filter setting
- Menu Lock indication
- Encryption enabled indication
- Microphone indication, Muted/Unmuted
- Remaining lifetime in percentage or time dependent on the type of battery

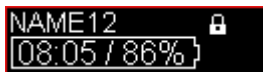

Screen 3:

- Wireless Channel name
- Menu Lock indication
- Remaining lifetime in percentage and/or time dependent on the type of battery

It is possible to change between the main screens with the up and down arrows.

How to navigate the menu system

The Handheld (N-HH-SL1) and Bodypack (N-BP-90 and N-BP-03) Transmitters contain the same menu structure.

To enter the Transmitter Menu, open the Transmitter and press the ENTER Button. Use the arrow buttons to navigate to the wanted function or setting and select with the Enter Button.

Use the Exit Button to exit a function, menu level or to exit back to the entry level.

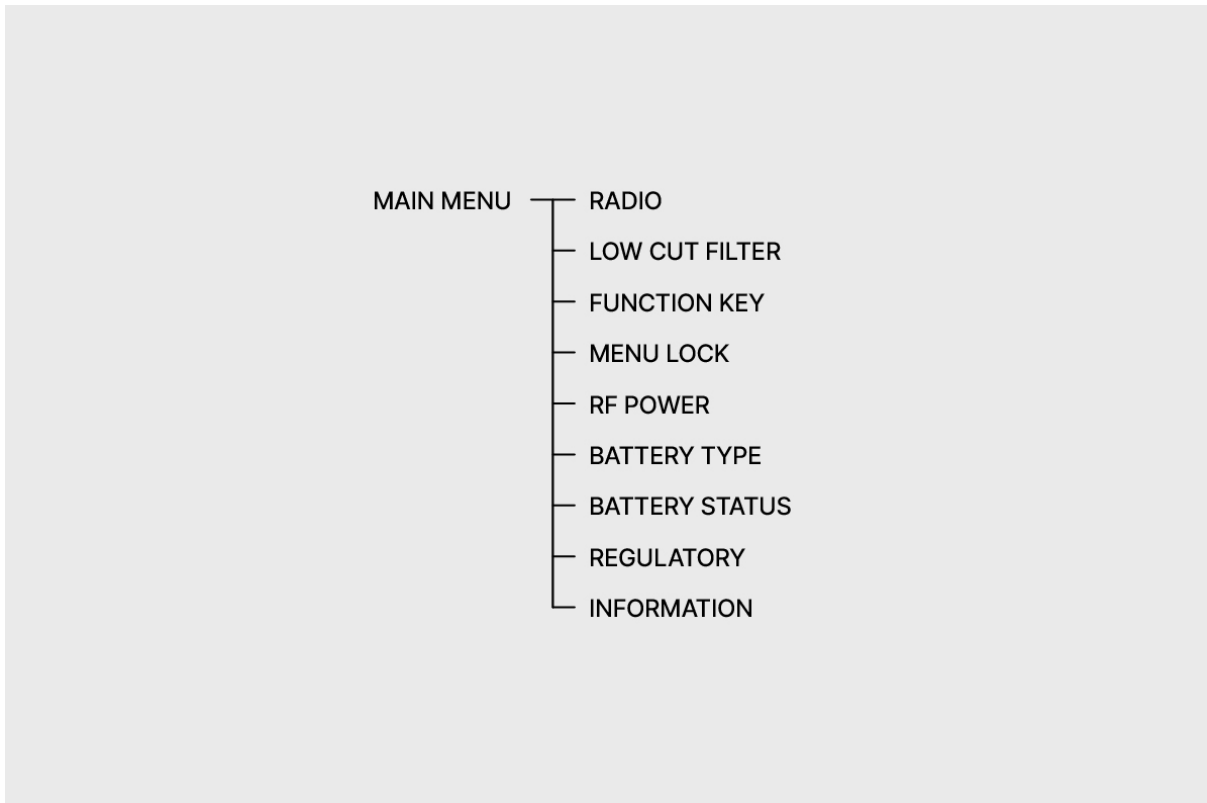

Functions and settings

The main menu contains all the different settings and status readouts relevant for the Transmitter.

Radio

(MENU → RADIO)

It is possible to set/change the frequency that the Wireless Channel should use.

The frequency can be selected in two ways. Either via Presets – pre-chosen frequencies divided in groups and channels or by manually selecting a frequency.

When the Preset option is selected, a group of Channels must be selected first. Afterwards, the Channel is selected. The corresponding frequency will be displayed on the Display.

When “manual” is selected, the frequency is chosen in two parts. The high part in steps of 1 MHz and the low part in steps of 25 kHz.

It is only possible to select a frequency that corresponds to the region/area that you are in.

Make sure that the Receiver is set to the correct region. If this setting is not correct, the system may not be compliant with local laws regarding radio transmissions.

Low cut

(MENU → LOW CUT)

Enables or disables the analog implemented 80Hz high-pass filter (low cut) in the microphone input stage on the Transmitter. Low-cut is disabled as default.

Function key

(MENU → FUNC KEY)

The Function Key (power button) on the Transmitter can work either as an audio mute (AF MUTE) or radio mute (RF MUTE) button, or it can be disabled to prevent a user from muting or turning off the Transmitter by mistake. When disabled, it will only work as a power button, enabling the user to turn on the Transmitter.

Possible settings:

- **AF MUTE** (Default)
- **RF MUTE**
- **OFF**

To turn off the Transmitter in this mode, remove the batteries.

Menu lock

(MENU → MENU LOCK)

It is possible to lock the four menu buttons on the Transmitter.

Holding the menu and the arrow up key for 3 seconds will unlock the menu. The menu will lock itself again after approximately 10 seconds.

This is to prevent the user from changing any settings of the Transmitter.

RF Power

(MENU → RF POWER)

Sets the RF power of the Transmitter to one of the following steps:

- Off (Muting of the RF stage)
- 1 mW
- 5 mW
- 10 mW
- 20 mW
- 50 mW

Note: Pressing the exit (X) button on the transmitter while powering the transmitter will disable the radio (RF MUTE). Restarting the transmitter will get it into normal operation mode.

Note: Due to local restrictions, only the valid RF level for the selected region/frequency can be chosen.

Make sure that the Receiver is set to the correct region. If this setting is not correct, the system may not be compliant with local laws regarding radio transmissions.

Battery Type

(MENU → BATT TYPE)

Select the type of AA batteries inserted in the Transmitter.

This setting is used to calculate the remaining lifetime of the battery in percentage.

If a DPA Rechargeable Battery is inserted in the Transmitter this setting is ignored.

Battery status

(MENU → BATT STATUS)

Shows the battery usage status.

If AA batteries are inserted in the Transmitter, this shows the remaining battery lifetime in percentage.

If a DPA Rechargeable Battery is inserted, the following information is shown:

- **Charge:** Remaining lifetime of the battery in hours and seconds.
- **Health:** Overall health of the battery. Estimated by the usage data of the battery.
- **Cycles:** Number of times the battery has been charged.
- **Temperature:** Internal temperature of the battery.

Regulatory (Only for N-BP1-90-B, N-BP1-03-B and N-HH1-SL1-B)

(MENU → REGULATORY)

Contains regulatory information (Electronical Label) regarding FCC (USA) and ISED (Canada).

Introduced in Firmware version 1.6.

Information

(MENU → INFO)

Contains information about the Transmitter such as device type number, serial number and Firmware version.

Firmware updates

DPA periodically updates the Firmware to add features and improve performance. Each DPA device must be updated to the same version of Firmware to function optimally. To download the newest Firmware version, visit the DPA website: <https://www.dpamicrophones.com/wireless/n-series/>

N-DR1 Receiver

The Receiver's Firmware can be updated via the DPA Audio Controller Software. The software can be downloaded free of charge from the DPA website.

The current Firmware version can be found in the Main Menu > Advanced > Device Information. Information about the model number and serial number can also be found here.

N-BP1 (N-BP1-90, N-BP1-03) & N-HH1-SL1 Transmitters

The Transmitter's Firmware can be updated via the infrared (IR) sync window on both the Receiver and the Transmitter.

The current Firmware version can be found via the Transmitter's Menu System.

The Receiver will install the version of Firmware in the Transmitter that matches the Firmware in the Receiver. If the Firmware in the Transmitter is newer than the version in the Receiver, then the Transmitter will be downgraded to match the Firmware in the Receiver.

Remember to periodically download and install the latest Firmware so your Receiver is using the latest version. Visit <https://www.dpamicrophones.com/wireless/n-series/> for information on the latest Firmware.

Below is the procedure for installing the Firmware in the Transmitter via IR.

1. Turn on the Receiver and Transmitter.
2. Enter the Main Menu and navigate to TX FW UPDATE.
3. Hold the Transmitter IR Sync Window 10 cm from the Receiver IR Sync Window.
4. Press the Navigation Wheel (SELECT) to start the procedure.
5. Synchronize the Transmitter to the Receiver to make sure that all settings are restored.

If the procedure fails, please try again, or contact your local DPA Sales Representative or Support Center.

Cleaning and maintenance

Cleaning

To remove dirt and germs from the wireless equipment, make sure to disconnect the unit from the mains or remove the batteries. Wipe down the surface with a slightly damp cloth containing soap and water. Be careful not to let any moisture spill into electrical contacts. Afterwards, leave the equipment to dry for 72 hours before reuse.

Disinfecting

To disinfect the wireless equipment, wipe down the surface with a slightly damp cloth treated with an isopropyl alcohol and water solution*. Make sure that no isopropyl alcohol enters the equipment.

* Pure isopropyl alcohol evaporates too quickly on surfaces to kill germs. By adding 20% water, its disinfectant properties will be extended for enough time to work properly.

UV-C light is also known to kill germs. With a wavelength of 185-254 nm, UVGI (ultraviolet germicidal irradiation) kills or inactivates microorganisms by destroying nucleic acids and disrupting their DNA, leaving them unable to perform vital cellular functions. The performance and condition of the wireless equipment will not be affected by a UV-C treatment.

Note: UV-C disinfection depends on line-of-sight, so make sure to expose as much of the equipment as possible and repeat treatment if necessary. Observe instructions for the use of your equipment and protect yourself from harmful radiation. Remove or protect microphone capsules before performing UV-C treatment.

Warning! Do not use sprays or fluids containing chemicals that could remove static electricity on or near the different elements. This could cause permanent damage.

Cleaning microphones

Please refer to the user manual of the microphone.

Batteries

AA Batteries (LR6 and HR6)

The N-Series Transmitters use LR6 and HR6 AA batteries for the Transmitters. Please refer to the [Bodypack](#) and [Handheld Transmitter](#) sections for information on how to change them in the specific Transmitter type.

If not in use for a longer period, remove the batteries from the battery compartment of the Transmitters.

LBPBP1 and LBPBH1 Rechargeable Batteries

The LBPBP1 and LBPBH1 Rechargeable Lithium-ion Battery packs are compatible with DPA N-Series Wireless Transmitters and Chargers.

See the Quick Start guide for information on insertion and removal of the battery packs.

Important Notice

These instructions apply to the rechargeable batteries (battery packs and installed battery packs), devices, chargers and products that specify their use.



Read battery and device instructions before use!

For safety, refer to the instruction manual for correct handling and use.

Warnings

The following instructions and precautions must always be observed to prevent personal injury and physical damage to equipment and surroundings.



WARNING!

Lithium-ion batteries are flammable, and may leak, vent, burst, ignite or flare when damaged or abused.

Risk of explosion, toxic release, fire and burns.

Do not open, deform, modify, disassemble, short circuit, heat above 60°C (140°F), incinerate or immerse in any liquid.

Do not subject the battery to mechanical shock or vibration.

Observe correct handling, installation and use of the battery. Always follow the manufacturer's instructions.

Keep the battery and electrical contact terminals clean and dry.

Keep away from children.

Never put batteries in mouth.

Do not touch any fluids of a leaking battery.

If any leaked fluid comes into contact with eyes, skin or clothing, immediately rinse thoroughly for at least 15 minutes with clean water without rubbing and seek medical attention.

If mist or vapors are accidentally inhaled, immediately move to an area with fresh air and seek medical attention.

Medical assistance is required for symptoms caused by accidental ingestion of battery fluid, contact with skin or eyes, or inhalation of battery combustion gases.

Do not use or charge battery packs with products other than those specified.
[FR-CA: *N'utilisez pas et ne chargez pas les batteries avec des produits autres que ceux spécifiés.*]

Do not use or charge a damaged, deformed, swollen, leaking or otherwise abnormal or defective battery.

Dispose of batteries properly.

First Use

A new battery pack must be charged before use. Charge a new battery pack in the charger, optionally while it is installed in the transmitter. It is recommended to fully charge the battery the first time.

Charging

Charge the battery packs under the temperature conditions specified in Specifications.

Discharging

Discharge the battery packs under the temperature conditions specified in Specifications.

Battery Life

The battery is a consumable item, and its capacity will gradually degrade with repeated use. The battery probably needs to be replaced, if the battery operating time and performance has been greatly reduced. The life of the battery varies depending on factors such as usage conditions, storage conditions and the characteristics of the individual battery pack.

Disposal

Please observe the appropriate rules of the country, state or region for proper disposal of batteries.



Lithium-ion batteries are recyclable and **SHOULD** be taken to separate recycling or household hazardous waste collection points.



Lithium-ion batteries and devices containing these batteries SHOULD NOT go in household garbage or recycling bins.

Always follow local regulations and your regional recycling scheme for battery disposal.

Specifications

Model	LBPBP1	LBPBH1
Category	Portable battery	
Type	Lithium-ion	
Nominal voltage	3.6 V	
Rated capacity	1.48 Ah	
Energy	5.33 Wh	
Operating temperature range	Discharging: -20 °C to +60 °C Charging: 0 °C to +60 °C	
Storage temperature range	-20 °C to +20 °C (recommended conditions for long-term storage: <70 % RH, ~50 % capacity)	
Dimensions, H×W×D	51.5 × 31.2 × 16.6 mm	101.1 × 17.7 × 15.9 mm
Mass	42 g	
Housing material	Molded PC/ABS	
Certifications	CE, UL Recognized (US and Canada), UN38.3, PSE, etc.	

Accessories

Included accessories

N-DR1

Description
Important Warranty and Safety Instructions
Quick Start Guide
2 x passive omnidirectional antennas
2 x 50 Ω coaxial cables for front mount of antennas
2 x BNC adaptors for front mount of antennas
EU power cord
Ethernet cable

N-BP1 (N-BP1-90 and N-BP1-03)

Description
Important Warranty and Safety Instructions
Quick Start Guide
Alkaline batteries
Passive omnidirectional antenna
Storage pouch

List of microphones for N-BP1-90 and N-BP1-03

Description		
2061-OL-C-F03	2061 Omni Mic, Loud SPL, Beige, 3-pin LEMO	Lavalier
4060-OP-C-B90	4060 CORE+ Omni Mic, Normal SPL, Black, MicroLock	Lavalier
4060-OP-C-B03	4060 CORE+ Omni Mic, Normal SPL, Black, 3-pin LEMO	Lavalier
4061-OP-C-F90	4061 CORE+ Omni Mic, Loud SPL, Black, MicroLock	Lavalier
4061-OP-C-F03	4061 CORE+ Omni Mic, Loud SPL, Black, MicroLock	Lavalier
4080-DC-D-B00	4080 CORE+ Cardioid Mic, Normal SPL, Black, MicroDot	Lavalier
4080-DC-D-B03	4080 CORE+ Cardioid Mic, Normal SPL, Black, 3-pin LEMO	Lavalier
6060-OC-U-B90	6061 CORE Omni Submini Mic, Normal SPL, Black, MicroLock	Lavalier
6060-OC-U-B03	6061 CORE Omni Submini Mic, Normal SPL, Black, 3-pin LEMO	Lavalier
6061-OC-U-C90	6061 CORE Omni Submini Mic, Loud SPL, Brown, MicroLock	Lavalier
6061-OC-U-C03	6061 CORE Omni Submini Mic, Loud SPL, Brown, 3-pin LEMO	Lavalier
4066-OP-A-F90-LH	4066 CORE+ Omni Headset Mic, Beige, MicroLock	Headset
4066-OP-A-F03-LH	4066 CORE+ Omni Headset Mic, Beige, 3-pin LEMO	Headset
4266-OP-F-B90-LE	4266 CORE+ Omni Flex Earset Mic, 110 mm Boom, Black, MicroLock	Earset
4266-OP-F-B03-LE	4266 CORE+ Omni Flex Earset Mic, 110 mm Boom, Black, 3-pin LEMO	Earset
4466-OP-R-C90	4466 CORE+ Omni Headset Mic, Brown, MicroLock	Headset

4466-OP-R-C03	4466 CORE+ Omni Headset Mic, Brown, 3-pin LEMO	Headset
6066-OC-R-F90	6066 CORE Omni Headset Mic, Beige, MicroLock	Headset
6066-OC-R-F03	6066 CORE Omni Headset Mic, Beige, 3-pin LEMO	Headset
4088-DC-A-F00-LH	4088 CORE Directional Headset Mic, Beige, MicroDot	
4288-DC-F-F00-MH	4288 CORE Directional Flex Headset Mic, 100 mm Boom, Beige, MicroDot	Headset
4488-DC-R-F00	4488 CORE Directional Headset Mic, Beige, MicroDot	Headset
4099-DC-1-199-V	4099 CORE Mic, Loud SPL with Clip for Violin	Instrument
4099-DC-1	4099 CORE Mic, Loud SPL	Instrument
4099-DC-2	4099 CORE Mic, Extreme SPL	Instrument

Please note that the above-mentioned microphones are only a small fraction of the huge number of variants that DPA Microphones offer in their portfolio that fit the N-Series bodypack transmitters. Use the configurator on the DPA web site to find much more about color, sensitivity, headset type, instrument type etc. that is relevant for the specific use case.

N-HH1-SL1

Description
Important Warranty and Safety Instructions
Quick Start Guide
Alkaline batteries
Clip for handheld microphone
Storage pouch

List of microphone cartridges for N- HH1-SL1

Description
2024-B-SL1 Vocal microphone (only available with the N-Series transmitter)
2028-B-SL1 Vocal microphone
4018V-B-SL1 Softboost Vocal Microphone (d:facto™)
4018VL-B-SL1 Linear Vocal Microphone (d:facto™)

Options and spare parts

Part number	Description
N-AO	2 Channel analog output module for N-DR1
TRY0101	Spare Battery Tray for N-BP1-90 and N-BP1-03
TRY0102	Spare Battery Tray for N-HH1-SL1
AWNS1	Spare antenna for Receiver
AWBP1	Spare antenna for N-BP1-90 and N-BP1-03
CALR90	Instrument cable for N-BP1-90 with Jack Rear Output, MicroLock®
CALR03	Instrument cable for N-BP1-90 with Jack Rear Output, 3-pin LEMO

CALS90	Instrument cable for N-BP1-90 with Jack Side Output, MicroLock®
CALS03	Instrument cable for N-BP1-90 with Jack Side Output, 3-pin LEMO
IDR0001	ID Rings for N-HH1-SL1
ANCB05	Antenna cable, RG58, 5 meters.
ANCB10	Antenna cable, RG213, 10 meters.
ANCB20	Antenna cable, RG213, 20 meters.
DAD9003	LEMO to MicroLock adaptor
ANT101P	Antenna, Omnidirectional, Passive, BNC, 430-1260 MHz
ANT202P	Antenna Directional, Passive, BNC, 420-1300 MHz
ANT202A	Antenna Directional, Active, BNC, 470- 960 MHz
ADS0208	Active Wideband Antenna Splitter 8 outputs + Cascade

Specifications

N-DR1

Digital wireless channels	2
Modulation	Digital
Radio frequency range	470 MHz to 870 MHz Region dependent. See frequency and RF power table to select the right system for your region
Number of simultaneous channels	16/8 MHz
Diversity	True Diversity (Receiver diversity)
Antenna cascade output	Active antenna cascade output. Maximum of 4 Receivers in cascade
Power for active antennas	12 VDC, max 250mA
Digital audio resolution	24bit / 48KHz
Analog audio dynamic range	126 dB (Typ. 1% THD @ 1KHz)
Digital audio dynamic range	126 dB (Typ. 1% THD @ 1KHz)
Audio frequency response	20Hz to 20KHz \pm 1 dB.
THD	<0.05%, 1KHz @ -12dBFS (Gain at 0dB)
Encryption	AES-256
Audio connectivity	Headphones, 6.3 mm jack Dante [®] , dual RJ45 Optional analog output, XLR female connector
Dante [®]	Primary and secondary connection. Redundancy and switching modes supported. 48KHz sample rate native. Up to 96KHz via sample rate converter
Separate control network	2 x RJ45, 100 Mbps. Network switching for cascading devices
User interface	Front panel menu system API for control via LAN
Manager software	DPA Audio Controller for Windows and macOS
Operation temperature	-10°C to +50°C (14°F to 122°F)
Storage temperature	-20°C to +50°C (4°F to 122°F)
Relative Humidity (RH)	Up to 90%
Dimension (H x W X D)	44 x 483 x 245 mm (1.7 x 19.0 x 9.6 in) (1U 19" full rack size)
Weight	3.6 kg (7.9 lbs.)

N-BP1-90

Radio frequency range	470 MHz to 870 MHz Region dependent. See frequency and RF power table to select the right system for your region
Audio Frequency range	20 – 20 kHz (Selectable 2 nd order HP @ 80 Hz)
Audio input connector	MicroLock [®]

Antenna connector	Coaxial socket (SMA)
Operation time	> 8 Hours (DPA rechargeable battery)
Battery types	2 x AA or DPA rechargeable battery
Dimension (H x W X D)	87 x 53 x 24 mm (3.4 x 2.1 x 0.9 in)
Weight (without batteries)	153 g (5.4 oz)

N-BP1-03

Radio frequency range	470 MHz to 870 MHz Region dependent. See frequency and RF power table to select the right system for your region
Audio Frequency range	20 Hz to 20 kHz (Selectable 2 nd order HP @ 80 Hz)
Audio input connector	LEMO 3 pin
Antenna connector	Coaxial socket (SMA)
Operation time @ 10 mW	> 8 Hours (DPA rechargeable battery)
Battery types	2 x AA or DPA rechargeable battery
Dimension (H x W X D)	87 x 53 x 24 mm (3.4 x 2.1 x 0.9 in)
Weight (without batteries)	153 g (5.4 oz)

N-HH1-SL1

Radio frequency range	470 MHz to 870 MHz Region dependent. See frequency and RF power table to select the right system for your region
Audio Frequency range	20 Hz to 20 kHz (Selectable 2 nd order HP @ 80 Hz)
Input connector	SL1 interface Threaded coupling: 1.25" diameter 28 UN-2A thread
Antenna	Integrated in the handle
Operation time @ 10 mW	> 7 Hours (DPA rechargeable battery)
Battery types	2 x AA or DPA rechargeable battery
Dimension (H x D)	192 x 37 mm (7.6 x 1.5 in)
Weight (without batteries)	213 g (7.5 oz)

Important safety instructions

N-DR1 N-Series Dual Channel Digital Wireless Receiver

1. Read these safety instructions and the User Manual of the product before use.
2. Keep the instructions and follow them.
3. This equipment is for professional use only. It is not intended for use in areas where children are present.
4. Heed all warnings.
5. Before connecting the product to the mains, verify that the supply voltage corresponds to the one indicated on the product (power supply voltage).
6. To reduce the risk of fire or electric shock, do not expose this apparatus to rain, liquids or moisture.
7. Do not install near any heat sources such as open flames, radiators, heat registers, stoves or other apparatus (including amplifiers) that produce heat.
8. The appliance should be situated so that its location does not interfere with its proper ventilation. Do not block or cover any ventilation openings.
9. Apparatus with CLASS I construction shall be connected to a mains socket outlet with a protective earthing connection.
10. Use a proper mains power cable based on your region. The manufacturing company will not assume any responsibility for the use of incorrect mains power cable.
11. Protect the power cord from being stepped on or pinched, particularly at plugs, convenience receptacles and the point where they exit from the apparatus.
12. Always turn off the apparatus before connecting or disconnecting any signal cables.
13. Only use attachments/accessories specified by the manufacturer.
14. The manufacturer will not assume any responsibility for the incorrect installation of the wireless Receiver.
15. Unplug this apparatus during lightning storms or when unused for extended periods of time.
16. All servicing must be done by qualified service personnel. Service is needed when the apparatus has been damaged in any way, such as power supply cord or plug is damaged, liquid has been spilled, objects have fallen into the apparatus, it has been exposed to rain or moisture, it does not operate normally, or it has been dropped.
17. Do not attempt to modify this product. Doing so could result in personal injury and/or product failure.
18. Operate this product within its specified operating temperature range.
19. Before activating the product, see specific chapter about the proper Firmware settings of the apparatus for your region/country about frequencies. Make sure that the apparatus is intended to be used in your region/country. The manufacturing company will not assume any responsibility for use of incorrect country/region setting.
20. The product is for indoor use only.

N-BP1 (N-BP1-90, N-BP1-03) & N-HH1-SL1 N-Series Wireless Microphone Transmitters

1. Read these safety instructions and the User Manual of the product before use.
2. Keep the instructions and follow them.
3. This equipment is for professional use only. It is not intended for use in areas where children are present.
4. Heed all warnings.
5. Always turn off the apparatus before connecting or disconnecting any signal cables.
6. Only use attachments/accessories specified by the manufacturer.
7. The manufacturer will not assume any responsibility for the incorrect use of the wireless Transmitter.
8. Remove the batteries from the apparatus during lightning storms or when unused for extended periods of time.
9. All servicing must be done by qualified service personnel. Service is needed when the apparatus has been damaged in any way, such as liquid has been spilled, objects have fallen into the apparatus, it has been exposed to rain or moisture, it does not operate normally, or it has been dropped.
10. Do not attempt to modify this product. Doing so could result in personal injury and/or product failure.
11. Operate this product within its specified operating temperature range.
12. Before activating the product, see specific chapter about the proper Firmware settings of the apparatus for your region/country about frequencies. Make sure that the apparatus is intended to be used in your region/country. The manufacturing company will not assume any responsibility for use of incorrect country/region setting.
13. The product is for indoor use only.

Information on disposal

Your product is marked with this symbol.

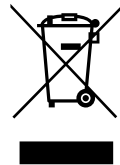

This symbol means that this product should be disposed of as used electrical and electronic products and as such, should not be mixed with general household waste. There is a separate collection system for these types of products. The solid bar under this symbol indicates that the product is put on the market after 13 August 2005.

Please follow your regional recycling scheme for batteries, packaging, and electronic waste.

Information on disposal for users (private households)

In the European Union

ATTENTION: If you want to dispose of this equipment, please do not use the ordinary trash can! Used electrical and electronic equipment must be treated separately and in accordance with legislation that requires proper treatment, recovery, and recycling of used electrical and electronic equipment. Following the implementation by member states, private households within the EU states may return their used electrical and electronic equipment to designated collection facilities

free of charge. In some countries your local retailer may also take back your old product free of charge if you purchase a similar new one. Please contact your local authority for further details.

If your used electrical or electronic equipment has batteries or accumulators, please dispose of these separately beforehand according to local requirements. By disposing of this product correctly you will help ensure that the waste undergoes the necessary treatment, recovery and recycling and thus prevent potential negative effects on the environment and human health which could otherwise arise due to inappropriate waste handling.

In other Countries outside the EU

If you wish to discard this product, please contact your local authorities, and ask for the correct method of disposal.

For Switzerland: Used electrical or electronic equipment can be returned free of charge to the dealer, even if you don't purchase a new product. Further collection facilities are listed on the homepage of

www.swico.ch or www.sens.ch.

Information on disposal for business users

In the European Union

ATTENTION: If the product is used for business purposes and you want to discard it: Please contact your DPA Microphones A/S dealer who will inform you about the take-back of the product.

You might be charged for the costs arising from take-back and recycling. Small products (and small amounts) might be taken back by your local collection facilities.

For Spain: please contact the established collection system or your local authority for take-back of your used products.

In other Countries outside the EU

If you wish to discard this product, please contact your local authorities and ask for the correct method of disposal.

Limited warranty

All DPA Microphones products are covered by a warranty for a minimum of two years.

The warranty is limited to the functionality of the device and such specifications as published by DPA Microphones. Regardless of an extended warranty period offered to distributors and suppliers, the warranty for customers cannot exceed two years from the date of purchase by the customer. Under

certain circumstances, the customer can be required to document the date of purchase. The purchase invoice serves as the warranty registration. The invoice must state the date of purchase as well as the name and serial number of the product.

dpamicrophones.com/warranty

Important product information

Licensing information

In certain areas, a special ministerial license may be required to operate this equipment. National authorities should be consulted to find these possible requirements. Changes or modifications not expressly approved by DPA Microphones could void your authorization to operate the equipment. Licensing of DPA Microphones' wireless microphone equipment is the user's responsibility, and depends on the user's classification, application and on the selected frequency. It is the equipment user's responsibility to contact the appropriate telecommunications authority concerning proper licensing before choosing frequencies.

Information to the user

EMC conformance testing is based on the use of supplied and recommended cable types. The use of other cable types may degrade EMC performance.

The N-DR1 Receivers power inlet contains a fuse. In the case that the fuse is blown, then make sure to replace it with a fuse of same type and value.

Type: 5x20mm, 250 Vac, F1.5 A

A blown fuse typically indicates that there is a fault on the device. Do not keep changing the fuse if it blows after you have changed it.

Contact your DPA Microphone service center or representative for instructions regarding service.

The N-DR1 Receiver contains a coin cell battery (CR 2032) driving the internal real-time clock. This battery is only to be replaced by a certified DPA Microphones service center.

USA and Canada

This device operates on a no-interference, no-protection basis. Should the user seek to obtain protection from other radio services operating in the same TV bands, a radio license is required. For further details, consult Innovation, Science and Economic Development Canada's Client Procedures Circular CPC-2-1-28, [Voluntary Licensing of License-Exempt Wireless Microphones in the TV Bands](#).

This device complies with Part 15 of the FCC Rules and contains license-exempt transmitter(s)/receiver(s) that comply with Innovation, Science and Economic Development Canada's license-exempt RSS standard(s).

Operation is subject to the following two conditions:

- (1) this device may not cause harmful interference, and
- (2) this device must accept any interference received, including interference that may cause undesired operation of the device.

L'émetteur/récepteur exempt de licence contenu dans le présent appareil est conforme aux CNR d'Innovation, Sciences et Développement économique Canada applicables aux appareils radio exempts de licence.

L'exploitation est autorisée aux deux conditions suivantes:

- (1) l'appareil ne doit pas produire de brouillage, et
- (2) l'appareil doit accepter tout brouillage radioélectrique subi, même si le brouillage est susceptible d'en compromettre le fonctionnement.

Changes or modifications made to this equipment not expressly approved by DPA Microphones may void the FCC authorization to operate this equipment.

This equipment complies with FCC and ISED radiation exposure limits set forth for an uncontrolled environment. This equipment should be installed and operated at a minimum distance of 0 cm between the radiator and your body. This transmitter must not be co-located or operating in conjunction with any other antenna or transmitter

This equipment has been tested and found to comply with the limits for a Class A digital device, pursuant to Part 15 of the FCC Rules. These limits are designed to provide reasonable protection against harmful interference when the equipment is operated in a commercial environment. This equipment generates, uses, and can radiate radio frequency energy and, if not installed and used in accordance with the instruction manual, may cause harmful interference to radio communications. Operation of this equipment in a residential area is likely to cause harmful interference in which case the user will be required to correct the interference at his own expense.

Regulatory Information and Electronic Labeling for N-BP1-90-B, N-BP1-03-B and N-HH1-SL1-B

The devices are identified by:

- N-BP1-90-B/N-BP1-03-B:
 - o FCC ID: NBP1 and NBP12
 - o IC: 28129-NBP1
- N-HH1-SL1-B:
 - o FCC ID: NHH1SL1 and NHH1SL12
 - o IC: 28129-NHH1SL1

Depending on your device's date of manufacture or firmware version, regulatory marks are provided in one of the following ways:

1. Physical Label

For all units, the FCC and ISED certification information can be found on the physical label.

2. Electronic Label (E-Label)

For devices running Firmware Version 1.6 or higher, regulatory information is also available electronically. To view the FCC ID, ISED Certification Number, and other compliance markings on the device screen:

1. Turn on the device.
2. Enter the menu system (Press the menu button)

3. Navigate to and select REGULATORY
4. Use the arrow keys to switch between the FCC and ISED regulatory information.

Region-dependent use of the wireless system

Please note that the N-Series system allows usage in many regions and areas of the world, but it is always the user's responsibility to ensure that the correct settings are applied for the region and that local restrictions are followed.

Please refer to the section Tuning the system for more information.

You can find more information about the various types of DPA N-Series Transmitters and Receivers that are made for specific regions, i.e. Europe, North Americas and so on via the DPA Webpage:

<https://www.dpamicrophones.com/wireless/n-series/>

CE DECLARATION OF CONFORMITY

Manufacturer: DPA Microphones A/S
Address: Kokkedal Industripark 101
DK 2980 Kokkedal
Denmark

Designated product: N-series Wireless System

- N-DR1, N-Series Dual Channel Digital Wireless Receiver w. DANTE Output
- N-DR1-AO, N-Series Dual Channel Digital Wireless Receiver w. DANTE and Analog Output
- N-BP1-03, N-Series Bodypack Transmitter, 3-pin LEMO
- N-BP1-90, N-Series Bodypack Transmitter, MicroLock
- N-HH1-SL1, N-Series Handheld Transmitter

The manufacturer hereby declares under his sole responsibility that all products supplied by DPA Microphones A/S meet the requirements in all relevant Union harmonization legislation, allowing it to bear the **CE marking**.

Applicable EU Directives:	Harmonized Standards Applied:
1. RoHS Directive (2011/65/EU)	1. EN 300 422-1 V2.2.1 – Harmonised Standard for access to radio spectrum
2. REACH Regulation 1907/2006/CE (209)	2. EN 301 489-1 V2.2.3 – Harmonised Standard for Electro Magnetic Compatibility
3. WEEE Directive 2012/19/EC	3. EN 301 489-9 V2.1.1 – Electro Magnetic Compatibility (EMC) standard for radio equipment and services
4. Safety standard IEC 62368-1:2018	4. EN 62311:2020 – Assessment of electronic and electrical equipment related to human exposure restrictions for electromagnetic fields (0 Hz - 300 GHz)
5. 2014/53/EU – Radio Equipment Directive (RED)	5. EN 62209-2:2010/A1:2019 – Human exposure to radio frequency fields from hand-held and body-mounted wireless communication devices (470 MHz - 785 MHz)
	6. EN 62479:2010 – Human exposure to electromagnetic fields (785 MHz - 870 MHz)

Date and place of issue:

26/05/2025, Kokkedal

Name & function:

Filali Bojattouy, QA Manager



Contact, Service & Support

Europe

Head office

DPA Microphones

Kokkedal Industripark 101

DK-2980 Kokkedal

Denmark

info@dpamicrophones.com

dpamicrophones.com

UK Sales Office

DPA Microphones UK

Unit 8 Colour House,

2/26 Bentley Road

London N1 4BY

United Kingdom

Tel. +44 20 3008 7530

info-UK@dpamicrophones.com

Americas

US Sales Office

DPA Microphones, Inc.

1500 Kansas Avenue, Unit 3A

Longmont, CO 80501

USA

Tel. +1 303-485-1025

Fax. +1 888-384-2170

InfoUSA@dpamicrophones.com