



APO-VX20-UC v2

Apollo Series Conference
Video Bar & Switcher

User Manual

Version: V1.0.0



Important Safety Instructions

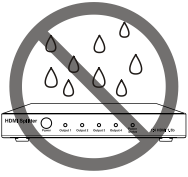

1. Do not expose this apparatus to rain, moisture, dripping or splashing and that no objects filled with liquids, such as vases, shall be placed on the apparatus.

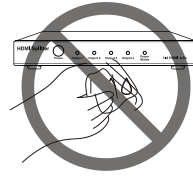

6. Clean this apparatus only with dry cloth.



2. Do not install or place this unit in a bookcase, built-in cabinet or in another confined space. Ensure the unit is well ventilated.

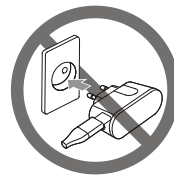

7. Unplug this apparatus during lightning storms or when unused for long periods of time.

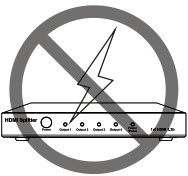

3. To prevent risk of electric shock or fire hazard due to overheating, do not obstruct the unit's ventilation openings with newspapers, tablecloths, curtains, and similar items.

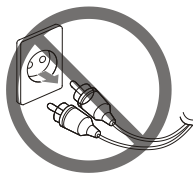

8. Protect the power cord from being walked on or pinched particularly at plugs.



4. Do not install near any heat sources such as radiators, heat registers, stoves, or other apparatus (including amplifiers) that produce heat.



9. Only use attachments / accessories specified by the manufacturer.



5. Do not place sources of naked flames, such as lighted candles, on the unit.

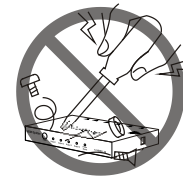

10. Refer all servicing to qualified service personnel.

Table of Contents

Introduction	3
Overview.....	3
Features	3
Package Contents	3
Specifications	3
Panel Description	4
Installation	5
Installation	5
Typical Application	6
Split Screen	9
Auto Switching	10
Pairing with Bluetooth Remote Controller	10
Screen Mirroring	11
Obtain IP Address	11
Web UI Control	11
Overview	12
Camera	12
Settings	13
General Settings	13
Video Settings	14
Audio Settings	15
Wi-Fi Settings	15
BYOD Settings	16
NTP Settings	17
Privacy and Security	17
System Settings	18
Support	18
Device Information	18
Firmware Upgrade	18
Support	18

Introduction

Overview

This product is an all-in-one meeting collaboration with ultra-wide angle 4K camera, microphone and speaker features, along with wired and wireless screen casting capability. It is ideal for applications at huddle/small/medium rooms.

Features

- Smart video conference collaboration with all-in-one solution of video speakerphone and camera
- Wired screen presentation via USB-C (with DP Alt mode) and HDMI
- Wireless BYOD via Airplay, Miracast and 4K Dongle
- Wide angle 4K video camera with DFOV 120°
- 8 x MEMS digital microphone arrays with a range of 8 meters and an angle of 180°
- 2 x 5W Stereo full range speakers with passive radiator bass enhancement
- Includes AEC (Acoustic Echo Cancellation), AGC (Automatic Gain Control), ANS (Automatic Noise Suppression) and full duplex mode communication to make all participants feel like they are in the same room
- Auto Framing / Speaker Tracking / Presenter Tracking / Individuals Gallery based on AI technology makes meetings more intimate and friendly
- Plug and play with excellent compatibility for OS and UC applications, e.g. Zoom, Teams, Webex, Tencent Meeting, etc
- Provides flexible control options of Web GUI and Remote Controller
- Built-in Wi-Fi.

Package Contents

1x APO-VX20-UC Video Bar
1x 24V 5A Power Supply (UK/US/EU/AU)
1x 5m HDMI Cable
1x 5m USB-B 3.0 Host Cable
1x Wall Mount Kit
1x Bluetooth Remote
1x Magnetic Lens Cap
1x Quickstart Guide

Specifications

Audio and Video	
Inputs/Outputs	1x USB-C Input 1x HDMI Input 1x HDMI Output
Supported Standards	RGB USB USB-Alt Mode
Maximum Pixel Clock	300Mhz
Speakerphone	
Microphone	4 x MEMS mic array, AEC ANS Pickup Range: 5 - 8m (16 - 26ft)
Speaker	2x 8 Watt
Camera	
Sensor	1/2.5", CMOS, Effective Pixel: 8.0M
Video Resolution	3840x2160p @30Hz 1920x1080p @60Hz
Output Encoding	MJPEG/YUV2/H.264/H.265 UVC 1.1
FOV	120°
Additional Features	White Balance: Auto Backlight Compensation: Auto DNR: 2D & 3D ePTZ: Supported 5x digital zoom Presenter Tracking: Supported
Communication and Control	
USB	1x USB-C: USB 3.2 Gen 2x1 Max Bandwidth: 10Gbps 1x USB-B: USB 3.2 1x1 Max Bandwidth: 5Gbps 1x USB-A: USB 3.2 1x1 Max Bandwidth: 5Gbps 1x USB-Mini: USB 2.0 Max Bandwidth 480Mbps
USB Protocols	UAC, UVC, USB HID

LAN	1x 8-pin RJ45
HDMI	HDMI 1.4 HDCP 2.2 EDID CEC
Wireless	IEEE 802.11ac 2.4Ghz, 5Ghz
Handheld Remote	Bluetooth
Power	
Power Supply	24V DC 5A
Power Consumption	Max: 40w Max with USB-C charging: 100w (60w max charging)
Environment	
Operating Temperature	0°C ~ 40°C (32°F to 104°F), 10% to 90%, non-condensing
Storage Temperature	-20°C ~ 60°C (-4°F to 140°F), 10% to 90%, non-condensing
Maximum BTU	Standard: 68 BTU/hr
Dimensions and Weight	
Length	699.4mm/27.54in
Width	126.82mm/4.99
Height	90mm/3.54in
Weight	2.42kgs/5.324lbs (with tabletop stand)
Regulatory	
Safety and Emission	CE FCC RoHS RCM EAC

Panel Description

Front Panel

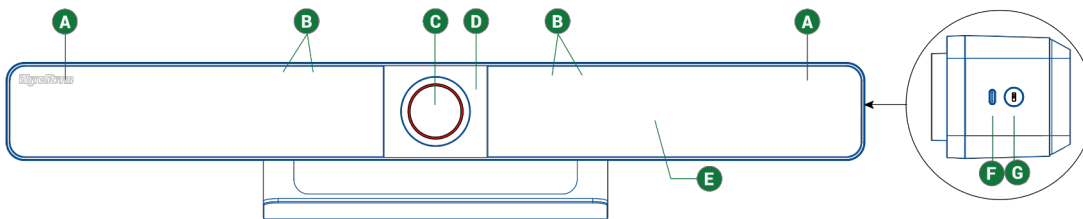

#	Name	Description
A	Speaker	2x Speakers for audio signal output
B	Microphone	8x Linear microphone arrays for picking up sound and voice location
C	Lens	Camera lens
D	Camera LED	<ul style="list-style-type: none"> Lighting White: The devices camera is active Off: The devices camera is inactive
E	Status LED	<ul style="list-style-type: none"> Blinking Orange: The device is booting Lighting White: The device is working properly. Blinking White: The device is in standby state. Quickly Blinking White: The device is being upgraded. Slowly Blinking White: The device is in sleep state. Lighting Red: The device's microphone is muted. Blinking Blue: The device is in Bluetooth pairing state
F	USB-C	Connect to the Dongle for pairing
G	Pairing Button	<ul style="list-style-type: none"> Press and hold this button for more than 2 seconds to start pairing with the blue-tooth remote controller. Quickly short press this button for 5 times to reset the device to factory defaults (the status LED blinks quickly). Short press the button once to enable OSD (this function requires that the IP Address OSD be enabled).

Rear Panel

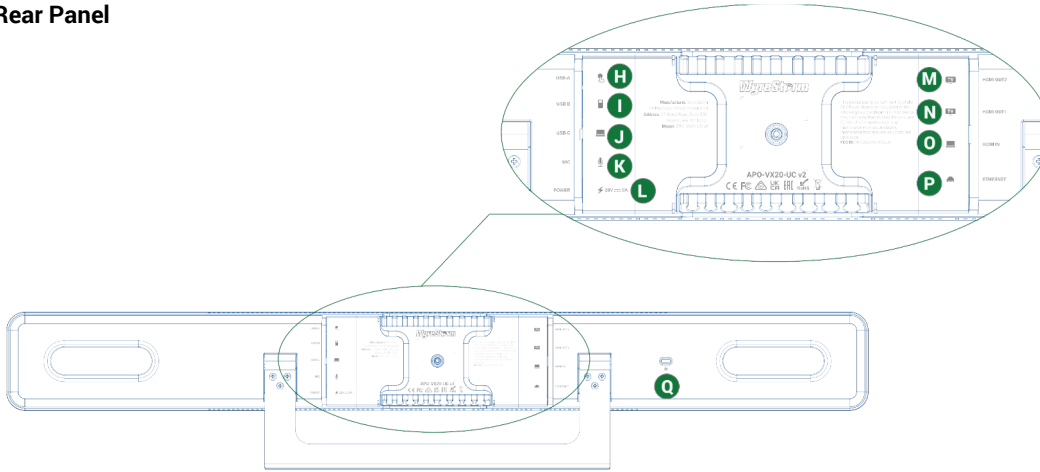

#	Name	Description
H	USB-A	USB 3.0 Type-A port. Connect to a USB device such as touch screen.
I	USB-B	USB 3.0 Type-B port. Connect to the room PC for meetings.
J	USB-C	USB 3.0 Type-C port. USB PD: 60W max Connect to the laptop for meetings.
K	MIC	Connect to an external microphone APO-SKY-MIC.
L	DC 20V/6A	Connect to the power adapter provided for DC 20V/6A input.
M	HDMI OUT2	HDMI 1.4 type-A female port. Connect to a HDMI display device or a capture card of the room PC.
N	HDMI OUT1	HDMI 2.0 type-A female port. Connect to a HDMI display device or a capture card of the room PC.
O	HDMI IN	HDMI 1.4 type-A female port. Connect to a laptop.
P	ETHERNET	Connect to a network device (e.g. network switch, wireless router, computer, etc.) for Airplay Mirroring signal input and LAN control (Web GUI & Telnet API).
Q		Kensington security slot

Installation

Note: Before installation, please ensure the device is disconnected from the power source.

Steps to install the device on a suitable location:

1. Drill holes on the wall you desire, then insert the expansion screws provided into the wall. Secure the wall hanging bracket on the wall using the mounting screws provided.

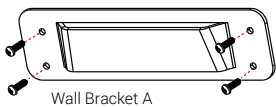

2. Remove the table stand from the VX20 and attach Bracket B to the device.

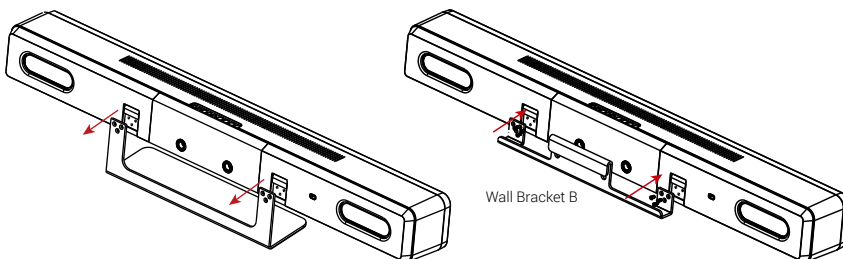

3. Attach the device's wall-mounted bracket to the wall hanging bracket on the wall.

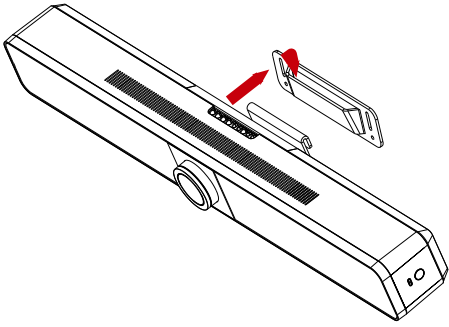

Typical Application

Note: Before wiring, disconnect the power from all devices. During wiring, connect and disconnect the cables gently.

After the device is connected to a computer, it can be detected by the system and specific applications in the name of the following:

Model: APO-VX20-UC-V2

Camera/Speaker/Microphone: APO-VX20-UC-V2.

Zoom Room PC

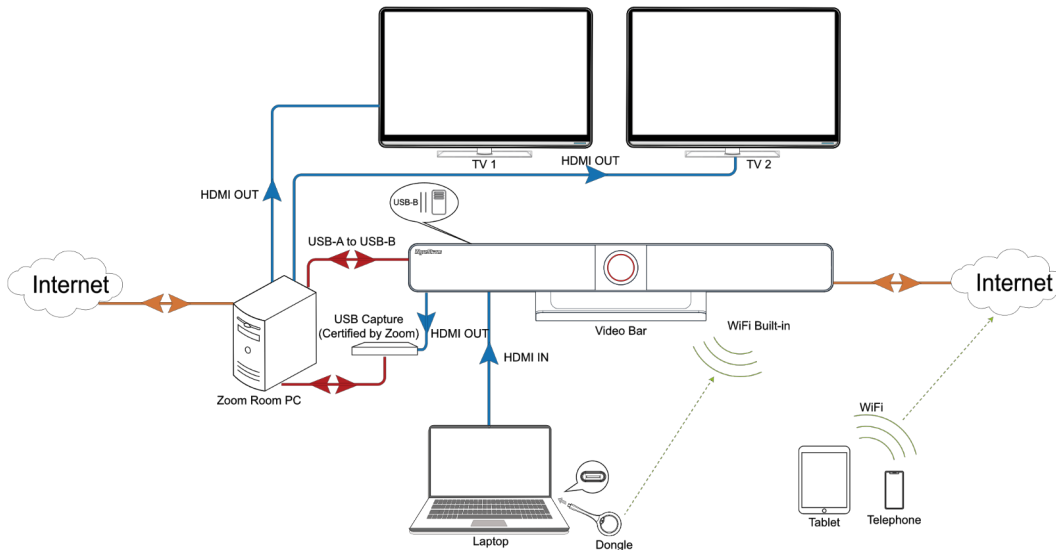

Primary device: Zoom Room PC

The Zoom Room PC is connected to the Video Bar via the USB-B port, receiving both camera and speakerphone signals. A Zoom-certified USB capture card is connected to the HDMI OUT port of the Video Bar, allowing the Video Bar to deliver content feed to the Zoom Room PC.

The content source can include: A laptop desktop (shared via a wired USB-C or HDMI IN connection, or through wireless casting using a dongle); a smartphone or tablet (shared via Wi-Fi).

BYOM

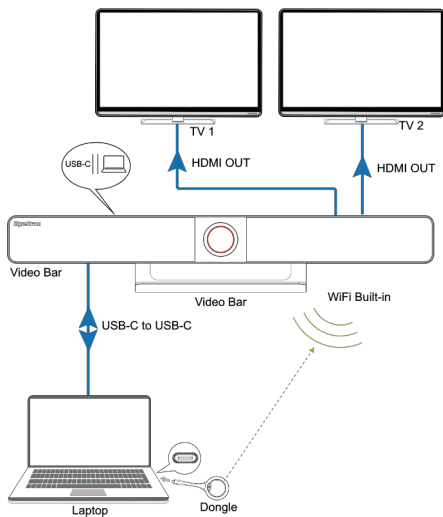

In this setup, there is no Room PC. Meetings are hosted directly through the Video Bar and a laptop, or used for local content sharing. The two TVs are connected to the Video Bar via HDMI OUT ports. The Video Bar provides a USB-A (Screen) port for connecting a touch display or other USB devices.

Content sharing via the following methods:

- The laptop sends content to the Video Bar via USB-C port, and receives camera and audio signals in return over the same USB-C port.
- The laptop connects to the Video Bar wirelessly via a USB-C dongle. The dongle receives camera and audio signals from the Video Bar, and transmit these signal to the laptop via its USB-C port.

If a touch display is used, USB HID signals (touch control) are sent back to the laptop via USB-C, USB-A and USB-C dongle in above two methods.

Zoom Room PC + BYOM

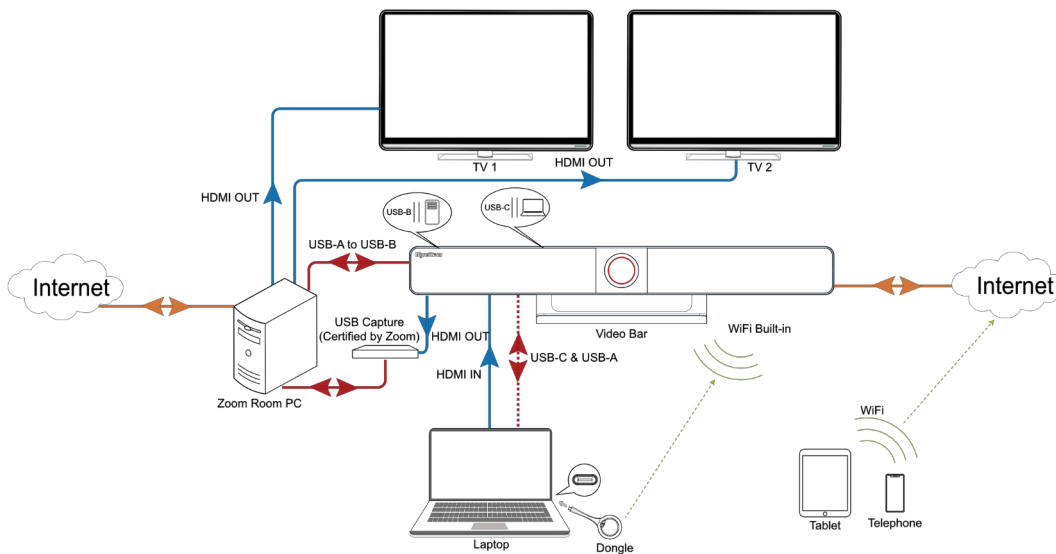

This setup supports both Zoom Room PC and BYOM.

The Zoom Room PC connects to the Video Bar via the USB 3.0-B (PC port) to receive camera and speakerphone signals. A Zoom-certified USB capture card is connected to the HDMI OUT of the Video Bar to send video output to the TV.

In this scenario, the Video Bar's built-in Wi-Fi should be configured to disable wireless conferencing and used only for content sharing.

Laptop connection methods when it is used to share contents:

- The laptop connects to the HDMI IN port of the Video Bar to share its desktop via HDMI.
- The laptop connects to the Video Bar wirelessly via a USB-C dongle, transmitting desktop content over the Bar's built-in Wi-Fi.

Laptop connection methods when it is used as BYOM:

- The laptop connects to the USB-C port on the Video Bar to send desktop content via DP, and receive camera and audio signals over the same cable.
- The laptop connects to the Video Bar's USB-C port via a USB-A to USB-C cable, and simultaneously to HDMI IN for desktop content.

The Video Bar returns camera and audio signals via USB-A.

Working modes:

- **Default (Zoom Room PC)** – when USB-C is not connected:
The Video Bar sends USB camera and speakerphone signals to the Zoom Room PC via USB 3.0-A (PC port).
- **BYOM** – when a laptop is connected via USB-C:
The Video Bar sends USB camera and speakerphone signals to the laptop via USB-C.
The laptop sends its local display content to the Video Bar via DP over USB-C.

BYOM + Room PC

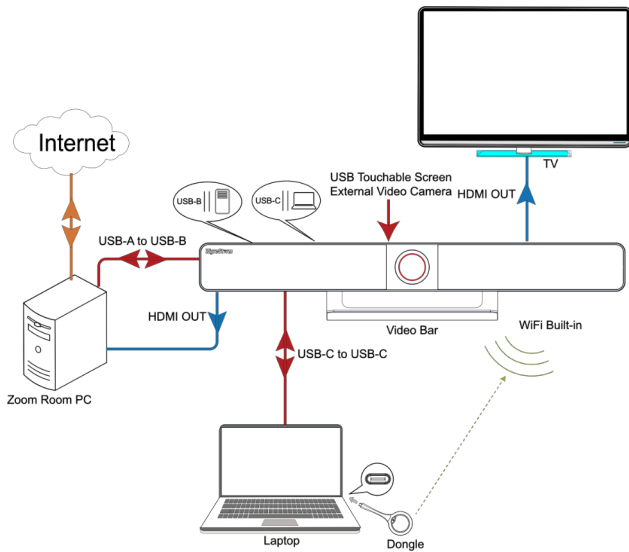

In this setup, the Video Bar is the primary device in the meeting room and connects to the TV via HDMI OUT.

The Room PC connects to the HDMI IN port of the Video Bar for content input and to the network via Ethernet. It also connects via USB 3.0-B (PC port) to receive camera and speakerphone signals from the Video Bar, enabling direct meetings. Content can be shared from the Room PC using VC apps that support Miracast, AirPlay, etc.

When using a laptop for BYOM, it can connect:

- Via USB-C to the Video Bar, sending desktop content over DP and receiving camera/audio signals over the same connection.
- Via a USB-C dongle, which transmits content wirelessly over the Video Bar's built-in Wi-Fi. The Video Bar returns camera and audio signals to the dongle, which passes them back to the laptop via USB.

In this scenario, once a USB-C cable or USB-C dongle initiates a meeting, the Video Bar automatically switches its AV routing to the laptop, effectively entering a BYOM override mode.

Note: As mentioned above, the USB-C dongles refer to the APO-DG2 and APO-DG2 PRO models. They support wireless screen sharing and wireless conferencing. The differences are shown in the table.

	Windows OS				Mac OS			
	Wireless Casting	Wireless Conferencing	Touchscreen HID	Keyboard & Mouse HID	Wireless Casting	Wireless Conferencing	Touchscreen HID	Keyboard & Mouse HID
APO-DG2	✓ (No App)	✓ (No App)	✓	x	✓ (No App)	✓ (No App)	✓	x
APO-DG2-PRO	✓ (No App)	✓ (App Enabled)	✓	x	✓ (No App)	✓ (No App)	x	x

Detail operations about the dongle, please refer to its own manual.

Microphone Cascading

The Video Bar supports connecting external microphone such as APO-SKY-MIC device via the MIC port. For detailed information about the APO-SKY-MIC, please refer to its own user manual.

Note: The Video Bar supports up to 5 daisy-chained microphones, with a maximum distance of 26m. When the video bar enters sleep mode, the cascaded microphone also enters sleep mode. Operations on the cascaded microphone will not wake up the main device.

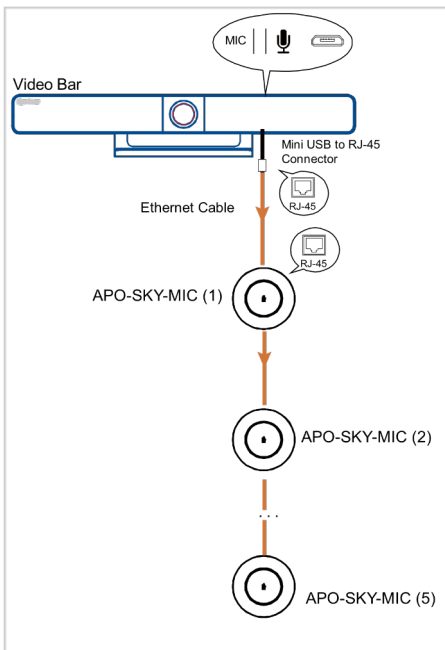

Split Screen

This function is only active when a single HDMI Out port (HDMI OUT 1 or HDMI OUT 2) is connected. When only one HDMI OUT port is connected to a display, two video sources are shown side by side on the screen, each occupying equal space (HDMI IN source and USB-C source can be shown as two screen simultaneously in this mode). If an additional HDMI OUT is connected while the function is active, the system will automatically switch to dual HDMI Out output mode.

Split Screen Source Switching

After Split Screen is enabled, the video input switching follows a Last-In-First-Out (LIFO) policy (refer to "Auto Switching" section to get detail information). Audio output will be from only the last active video source among the two screens.

When a signal source is lost during split screen:

- If one video source is lost, the system will switch to Single Screen mode.
- If the single screen's video source is lost, the system will detect the last connected wired video source signal.
- Wireless sources such as BYOD or USB Dongle will be disconnected if preempted and will not automatically reconnect.
- If no video signal is detected, the system will enter the GUIDE screen.

Use Remote Controller

When using the remote controller, pressing the left or right arrow buttons will move the selection cursor between the two screens. Pressing the Home button will switch the selected screen to Single Screen display mode.

The unselected wireless video source will be disconnected, while wired video sources will remain connected; however, all sources must be reconnected manually to re-enter Split Screen mode.

Auto Switching

Automatic Switching for Video

The video automatic switching follows a "last-in-first-out" (LIFO) principle. Regardless of whether the input is wired or wireless, the newly connected source will take priority and be output to the HDMI OUT.

1. The most recently input video will replace the earliest connected video, while any other unaffected video sources remain unchanged. Only the audio from the latest active video stream will be output.
2. When the current video source is lost, the system will revert to the previously connected video source signal. (For wireless screen sharing BYOD and 4K dongle, once preempted, the connection will be disconnected and cannot be restored automatically.)
3. If only one output is connected and two video sources are being played in dual view (Split Screen), connect a new video source input to the device, the new connected source will replace the one that displays longer on screen (Refer to "Split Screen Instruction" to get other information about Split Screen).
4. If all video sources are removed, the device will output the Guide Screen picture finally.

Automatic Switching for USB HOST

USB hosts the device supported mainly include: Room PC (USB-B), Laptop (USB-C), and Wireless. The automatic switching principle is "Last-In-First-Out", that is, the last connected USB HOST will be switched to, and if the currently switched USB HOST is removed, it will fall back to the last selected USB host.

For 4K dongle USB host, when a new 4K dongle is connected and presses "Wireless Conference Button", the USB host will switch to this 4K dongle USB. When remove the currently connected 4K dongle, the USB host will switch to the USB-C or USB-B port (the one with active device connected) selected last time. If both the two ports have no active device connected, it will switch to the default USB-B port.

Pairing with Bluetooth Remote Controller

The device can be controlled by the Bluetooth remote controller provided after they have been paired with each other successfully. To pair with the Bluetooth remote controller:

1. Press and hold the pairing button on the enclosure's left side, the status LED will blink blue, which indicates that the device enters Bluetooth pairing mode.
2. Press any button on remote controller, "Remote Control Connected" will appear on the display screen, indicating that Bluetooth pairing between the remote controller and the device is successful. Now you can use the remote controller to control the device with ease.

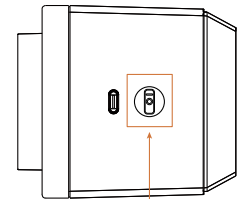

The following briefly introduces the functions of the remote controller buttons.



Button	Description
	Button to make the device pair with Apollo VX20. See Bluetooth Remote Pairing for more information.
	Press to answer calls*
	Press to disconnect calls.*
	Press to revert back to the default camera view.**
	Press to perform ePTZ functions.**
	Press and hold for 3s to save current camera view to preset 1 or 2. Single press to switch the camera view to either preset.**

Button	Description
	Press to toggle between mute and unmute.
	Press to adjust the volume. Press and hold to adjust the volume continuously.
	Press to toggle between Auto Framing, Presenter/ Speaker Tracking or turn off advanced functions.
	Press to adjust the zoom. Press and hold to adjust the zoom continuously.

*Function only available when connected to a mobile device via Bluetooth.
**Function only available when Tracking mode is turned off.

Screen Mirroring

With screen mirroring support, the device allows users to share multimedia content wirelessly from their mobile devices on any HDMI displays over Airplay Mirroring and Miracast.

Note: The following outlines only the common operating steps. The screen mirroring functionality may vary slightly across different versions of the devices. Please refer to their user manual of your specific product for detailed usage instructions.

Using an Apple Device

1. Connect your iPhone/iPad/Mac to the network on which the device runs.
2. Open Control Center on your Apple device, tap to select appropriate mirroring device from the pop-up menu

Using an Android Device

1. Enable the Wi-Fi or WLAN feature of your mobile device.
2. On your mobile device, swipe down from the top and tap "SmartView" or "Wireless Projection" to select an appropriate mirroring device from the pop-up CONNECT menu.

Using a Windows PC

1. Enable the Wi-Fi or WLAN feature of your PC.
2. On your PC, press the combination "Windows + K" to select appropriate mirroring device from the pop-up menu.

Obtain IP Address

Users view the IP address via the OSD. The OSD can be enabled using the following methods:

- Display "Guide" screen;
- Press and hold "Home" button on the remote controller for 2s to show OSD that includes IP address, model name, etc.
- Short press the "Pairing" button once to enable OSD.

Web UI Control

The Web UI designed for this device allows for basic settings. It can be accessed through a web browser, e.g. Chrome, Safari, Firefox, etc.

Default IP mode for this device is DHCP.

To access the Web UI page:

1. Connect the Ethernet port of the device to a local area network. (Ensure there's a DHCP server in the network so that the switcher can obtain a valid IP address.)
2. Connect a PC to the same network as the device.
3. Input the device's IP address in the browser and press Enter, the following window will pop up.

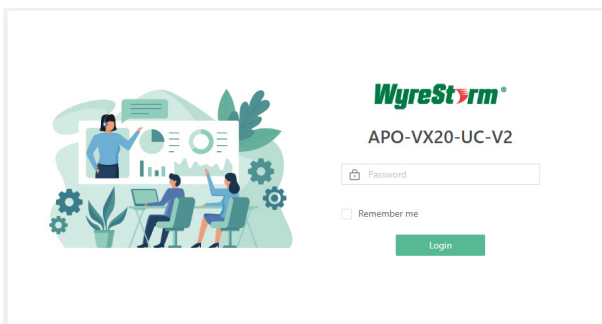

4. Input the user name and password (default user name & password: admin) and click Login.
5. When login web UI first time, after clicking "Login", users will enter the following window to change login password. Input new password and click "Apply" to enter the main page.

Please change your password to continue

New Password:

Verify Password:

Password must be 4 to 16 characters in length (alphanumeric only).

Apply

Note: Password must be 4 to 16 characters in length (alphanumeric only).

Firmware Version:	V1.1.2
Serial Number:	BC341B22846FFC
HDMI IN:	Disconnected
Type-C IN:	Disconnected
HDMI OUT 1:	Disconnected
HDMI OUT 2:	Disconnected

The main page includes Overview, Camera, Settings and Support tabs.

- **Overview:** Offers basic information of the device.
- **Camera:** Offers settings of camera parameters.
- **Settings:** Offers basic settings of Video, Wi-Fi, BYOD, etc.
- **Support:** Offers firmware update function and device information.
- **Log Out:** Click to logout the web UI and back to login page.

Overview

This page offers firmware version, serial number, input connection status, and HDMI output connection status of the device.

Camera

Tracking Mode: Auto Framing

Tracking Effect: Smooth

Tracking Speed: Slow

Mirror:

Powerline Frequency (Anti Flicker): 50Hz

WDR: Low High Default

Preview Button	Click to start preview mode, where the video feed from the camera will be displayed in this frame for real-time preview (note that the camera will be unavailable for use in other software during preview). All settings will be reflected live in this view. To exit preview mode, simply move the mouse to the center of the screen and click the black square.
Tracking Mode	<ul style="list-style-type: none"> • Auto Framing (default setting): Based on AI face recognition algorithm, the camera will monitor in real-time the positional changes of individuals in the meeting venue, automatically adjusting angles and focal lengths to ensure that the target person is framed while maintaining optimal clarity of their facial features. • Speaker Tracking: Camera will locate the speaker according to the device's array microphones, automatically select and frame the speaker, providing a close-up view. • Presenter Tracking: Camera automatically identifies the first speaker and continuously tracks the presenter in real-time. • Individuals Gallery: Camera identifies individuals in the frame and generates a multi-view display in left-to-right order. When more than four people are detected in the frame, the tracking mode will automatically switch to "Auto Framing" mode. • Off: When tracking mode is set to off, users can adjust the focal length to zoom in or out of the scene by moving the circular slider. To pan the camera view up, down, left, or right, click the respective arrow keys on the left side.
Tracking Effect	Tracking effect is available when Auto Framing is enabled. <ul style="list-style-type: none"> • Smooth (default setting): The tracking image moves smoothly in the frame. • Immediate: The tracking image switches from one to another immediately in the frame.
Tracking Speed	Tracking speed is available when Auto Framing is enabled. <ul style="list-style-type: none"> • Slow (default setting) /Normal/Fast
	When tracking mode is off, users can adjust the focal length to zoom in or out of the scene by moving the circular slider. To pan the camera view up, down, left, or right, click the respective arrow keys on the left side.
Preset 1/2/3/4	When tracking mode is off, click "Set" to save current camera view to this preset. Click "Load" to upload the saved camera view from the selected preset.
Mirror	Mirror image function. <ul style="list-style-type: none"> • On: To flip the image horizontally. • Off (default setting): Not to flip the image horizontally.
Powerline Frequency (Anti Flicker)	Change the frequency to prevent flicker in the video. <ul style="list-style-type: none"> • 50Hz (default setting) • 60Hz
WDR	Use the slider to set camera's WDR. Default value: 0, range: -7~7.

Settings

General Settings

▼ General Settings

Device Name _____

Device Name:

The device name must be 1 to 31 characters long, using only letters, numbers, spaces, hyphens, or underscores. It must start and end with a letter or a number.

Note: Changing the device name will modify the SSID at the same time, and the Type-C Dongle needs to re-pairing.

IP Settings

IP Method: Static DHCP

IP Address:

Subnet:

Gateway:

Primary DNS:

Secondary DNS:

Note: LAN Module will automatically reboot after changing Network setting.

IP Conflict Detection _____

IP Conflict Detection:

Device Name	<p>Redefine the device name to an easy to remember one. Note: The name must be 1~20 characters in length, including letters, numbers, "_" or "-". By default, it's set as APO-VX20-UC-V2. Apply: Click to save and perform above settings.</p> <p>Note: The device name is as same as the soft AP SSID. If you change to a new device name, you need to re-pair Dongle with this device as well.</p>
IP Settings	<ul style="list-style-type: none"> • IP Method: Static / DHCP (default setting). • IP Address: Set IP address manually when Static mode is selected. • Subnet: Set subnet mask manually when Static mode is selected. • Gateway: Set gateway address manually for the device to communicate with another network that uses different communication protocols when Static mode is selected. • Apply: Click to save and perform above IP settings. (LAN module will reboot automatically once IP settings are changed). <p>Note: When "Static" is selected, please ensure your PC is in the same network segment as the camera. Please wait for 2-3 minutes for the camera's LAN module to reboot and reconnect after the network setting is changed.</p>
IP Conflict Detection	Set IP conflict detection function to on/off. The default setting is on.

Video Settings

Video Settings

Camera Out

HD Mode:

Camera Resolution:

Output

	Timing:	HDCP:
HDMI OUT1:	<input type="text" value="Auto"/>	NO HDCP
HDMI OUT2:	<input type="text" value="Auto"/>	NO HDCP

CEC

CEC:

HDMI OUT1:	One Touch Play: <input type="text" value="40 04"/>
	Standby: <input type="text" value="ff 36"/>
HDMI OUT2:	One Touch Play: <input type="text" value="40 04"/>
	Standby: <input type="text" value="ff 36"/>

CEC command just supports Hex format with a maximum of 16 byte (example: 40 04).

CEC Test

Camera Out	<p>HD Mode:</p> <ul style="list-style-type: none"> • On (default setting): Turn on for better image quality. • Off: Turn off for better compatibility. <p>Camera Resolution: Select camera resolution among 4K and below (default), 1080P and below and 720P and below. When HD is set to on:</p> <ul style="list-style-type: none"> • 4K and below: resolution supports from 720P to 4K; • 1080P and below: resolution supports from 720P to 1080P; • 720P and below: resolution supports 720P.
Output	<p>Timing: Set output resolution for the device.</p> <ul style="list-style-type: none"> • Auto (default setting): Select to output the maximum resolution supported by the display based on the display's EDID. • Resolution range list: Select a desired output resolution from the dropdown menu to output this fixed resolution. <p>HDCP: Shows HDCP of HDMI OUT 1/2.</p>

CEC	<p>CEC:</p> <ul style="list-style-type: none"> • On (default setting)/Off: Select to enable/disable CEC control. • One Touch play: Enter the CEC one touch play command in hex of the controlled display device. For more information about the command, see the user guide of your display device. By default, it's set as "80 04". • Standby: Enter the CEC standby command in hex of the controlled display device. For more information about the command, see the user guide of your display device. By default, it's set as "80 36". <p>Apply: Click to save and perform above settings. Load Default: Click to load default settings.</p>
CEC Test	One Touch Play/Standby: Click to test if command setting takes effect.

Audio Settings

▼ Audio Settings

Expansion Mic

Expansion Mic only:

Expansion Mic Mute Button

Mic Mute Button:

Audio Out

Built-in Speakers HDMI Out Priority Built-in Speakers & HDMI Out

Expansion Mic	Expansion Mic only (ON/OFF): When this function is enabled, only the cascaded microphone can pick up voice. Default setting: OFF.
Expansion Mic Mute Button	Mic Mute Button: Click to mute / unmute expansion mic. Default setting: On (mute).
Audio Out	<ul style="list-style-type: none"> • Built-in Speakers (default): The audio output is exclusively through the device's built-in speakers. • HDMI Out Priority: When the HDMI display is connected to HDMI OUT 1/2, the audio is output through the connected display. If no display is connected to HDMI OUT 1/2, the audio is output through the device's built-in speakers. • Built-in & Speakers: The audio is output simultaneously through both the display connected to HDMI OUT and the built-in speakers. <p>Apply & Reboot: Click to reboot the device and apply the audio out settings.</p>

Wi-Fi Settings

▼ Wi-Fi Settings

Built-in Wi-Fi

Band: 5GHz

Channel: Auto Manual

Soft AP

Soft AP:

Soft AP Router:

Password:

The password must be 8 to 20 characters long (letters, numbers, "_" or "-" only)

Built-in Wi-Fi	<p>Band: 5GHz</p> <p>Channel:</p> <ul style="list-style-type: none"> • Auto (default setting): The device selects a wireless channel for itself automatically. • Manual: Assign a wireless channel for the device manually. <p>Apply: Click to save and perform above settings.</p>
Soft AP	<p>Soft AP: On (default setting) /Off.</p> <p>Soft AP Router: On (default setting) /Off.</p> <p>Password: Configure the soft AP password. By default, it is set as 12345678.</p> <p>Apply: Click to save and perform above settings.</p>

BYOD Settings

BYOD Settings

BYOD

BYOD:

Access Code: Auto

Manual

0000-9999 or blank

Guide Screen

Guide Screen:

Image in jp(e)g format with 1920x1080 resolution

Screen Off:

Delay Time:

0-30 minutes

Guide OSD:

1 to 8 characters in length (alphanumeric only)

IP Address OSD:

<p>BYOD</p>	<p>BYOD: On (default setting)/Off</p> <p>Access Code: The access code is used to help prevent users from accidentally connecting to an unintended device and protect from an unauthorized access.</p> <ul style="list-style-type: none"> • Auto: The device will randomly generate a four-digit access code in the following cases: <ul style="list-style-type: none"> • The device switches to Guide Screen for output. • The device reboots. • Manual: Select to input a four-digit code. By default, it is set as blank. <p>Apply: Click to save and perform above settings.</p>
<p>Guide Screen</p>	<p>Guide Screen: Click to select a Guide Screen image in jp(e)g format of 1920x1080 and upload to the device.</p> <p>Restore the default Image: Click to restore the guide screen to the default image.</p> <p>Screen Off: By default, this function is set to on, meaning the screen will automatically turn off after 60 seconds of inactivity. When set it to off, the screen will not automatically turn off.</p> <p>Delay Time: When "Delay Time" is set, the system waits for the specified number of minutes before starting a 60-second countdown. After the countdown, the HDMI outputs will be automatically turned off.</p> <p>Guide OSD: Enable / disable displaying Guide screen name. Default setting: ON, the Guide screen name is shown on the Guide screen. Input a Guide screen name on the box. Default: Guide.</p> <p>Note: The length of the name must be in 1~8 characters (alphanumeric only).</p> <p>IP Address OSD: Enable / disable to show IP address and WiFi password on the connected display. Default setting: ON.</p>

NTP Settings

▼ NTP Settings

NTP:

Date:

Time:

Time Zone:

NTP Server:

If the NTP address is a domain address, please ensure that DNS is configured correctly.

NTP	Set the NTP to on/off. Default setting: Off. <ul style="list-style-type: none"> On: Select to synchronize the time with the NTP time server to obtain real time information once the device is powered on. The NTP server should be any server on internet or that includes RTC chip or battery in the same local area network as the device. (Recommended settings, since the time and date setting will restore to factory defaults upon each booting if a NTP time server is not in use.) Off: Select not to synchronize with the NTP time server after the device is powered on.
Date	Set and display the date. The date will start from 1970-01-01 each time the device is booting if NTP Time Server is not configured or not available.
Time	Set and display the time.
Time Zone	Click the drop-down menu to select a time zone. Default setting: 00:00 Etc/UTC
NTP Server	Input the time server address when set the Use Time Server (NTP) to on.
Apply	Click to perform the NTP settings.

Privacy and Security

▼ Privacy & Security

Telnet Authentication

Enable:

HTTPS

Enable:

Telnet Authentication	Enable / disable telnet authentication. Default setting: Disable.
HTTPS	Click to enable HTTPS authentication service or disable HTTPS authentication service. Default setting: ON.

System Settings

System Settings

Login

Current Password:

New Password:

Verify Password:

Password must be 4 to 16 characters in length (alphanumeric only).

Apply

System

Factory Reset

Reboot

Export Log

Login	Set a new password to login Web UI.
Apply	Click to save and perform above settings.
System	<ul style="list-style-type: none">• Factory Reset: Click to set the device to factory defaults.• Reboot: Click to reboot the device.• Export Log: Click to export the log file to local PC.

Support

Device Information

Device Information

Device Model: APO-VX20-UC-V2

Current Version: V1.1.2 

Build Time: 2025.09.25 02:08:58

Serial Number: BC341B22846FFC

Displays device model, current version and build time.

Move the mouse to the information icon to show detailed version information.

Current Version: V1.1.2  V1.0.6 V1.0.38 V1.0.102 010124080102 V3.0.1 V2.0.105

Firmware Update

Firmware Update

Select the firmware files

Upgrade & Reboot

Note: Do not unplug the device while upgrading.

Click "Select the firmware files" to upload the upgrade file from local PC and click "Upgrade & Reboot" to upload it for upgrade.

Note: Do not unplug the device during the upgrading process.

Support

Support

Toll free: (844)-280-WYRE (9973)

Email: support@wyrestorm.com

This section supports support telephone number and Email. Click the green email address to select how you want to send an email to this address.

